

Single Frequency Network (SFN) over ATSC MDTV (M/H) Framework



Henry Douglas Rodrigues, Linear Industries Inc.

SFN General Overview

- Two or more equipments transmitting:
 - The same signal
 - At the same time
 - In the same frequency
- Types of SFN
 - Distributed
 - Repeated



Distributed SFN

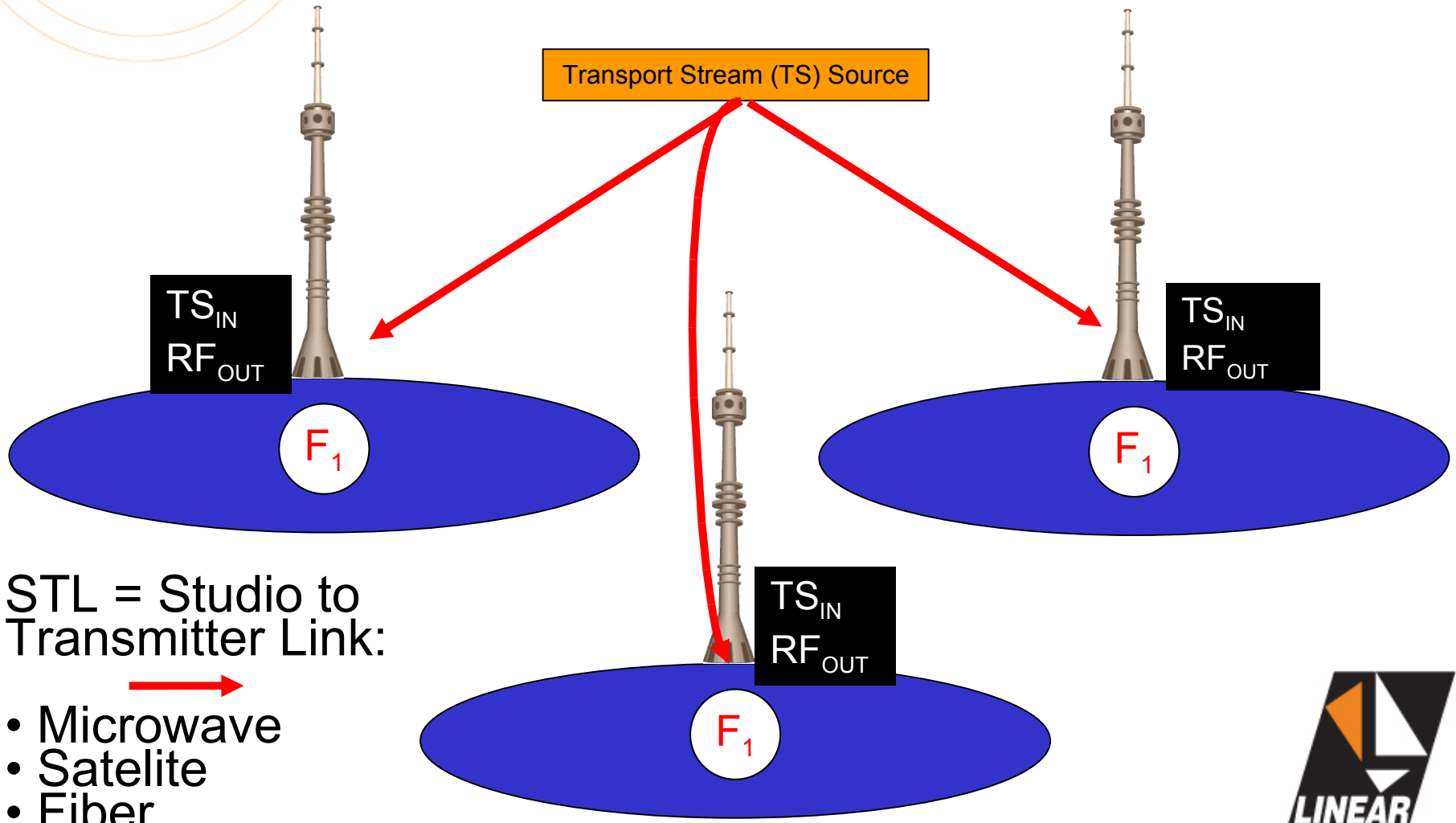

Repeated SFN

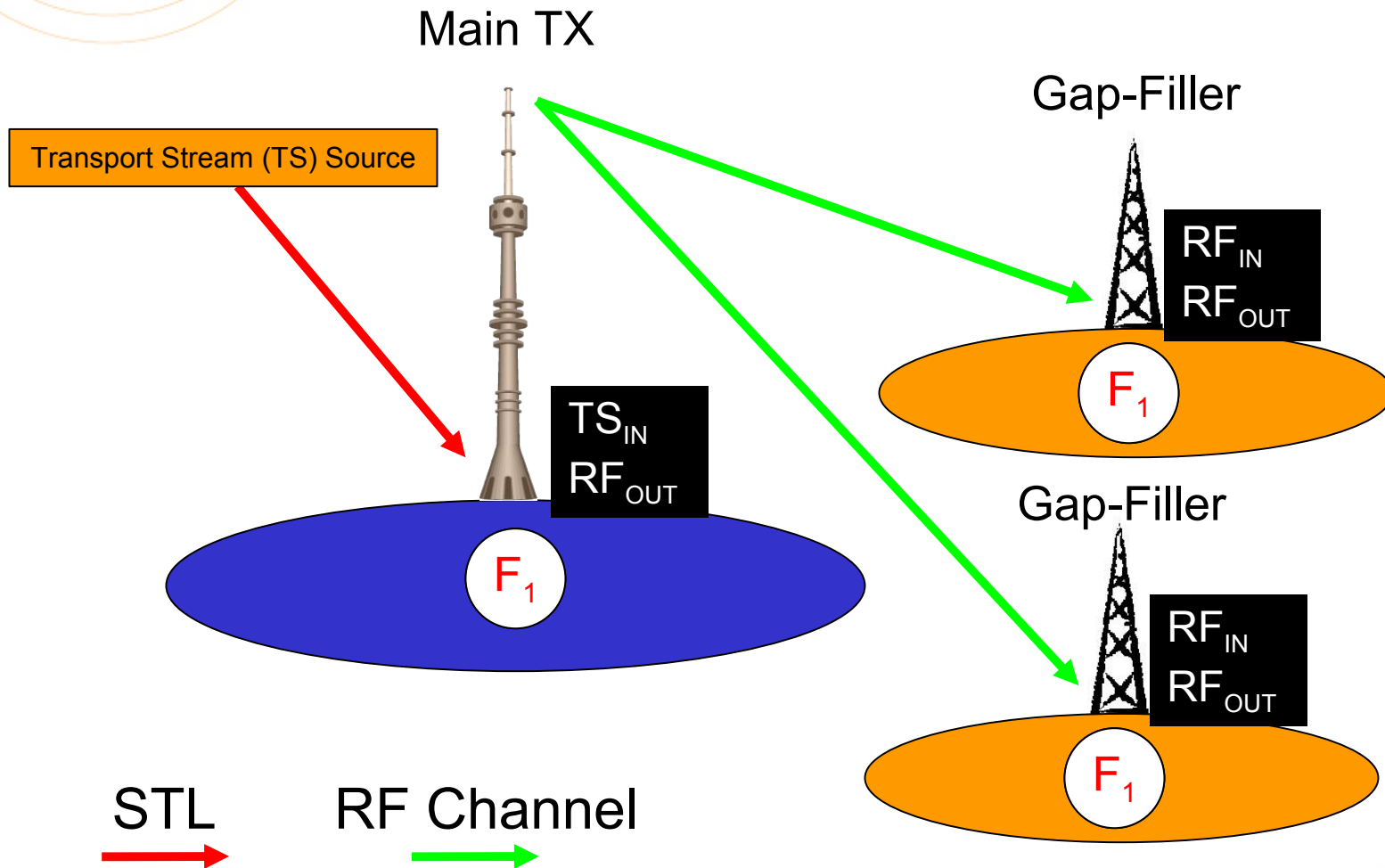

Distributed vs Repeated SFN

Advantages

Disadvantages

Distributed

- Reliability – all SFN transmitters works independently.
- No power limitation.
- No Signal to Noise degradation.
- Zero echo delay.

- Need for Studio to Transmitter Link (STL).

Repeated

- No need for STL link, as long as the main TX signal may be received.

- If main TX fails, all gap-fillers will go out of service as well.
- Power limitation due to feedback coupling.
- Signal to Noise degradation.
- Min. delay = transit delay.



ATSC SFN

Two possible solutions:

- A/110B: Synchronization Standard For Distributed Transmission, Revision B (October 2002)
- SFN over ATSC M/H
 - Info: from the receiver point of view, it doesn't matter which solution was adopted.



ATSC M/H Overview

- Dual stream system: Main service + M/H service.
- Both streams are multiplexed and transmitted on the same 6 MHz channel.

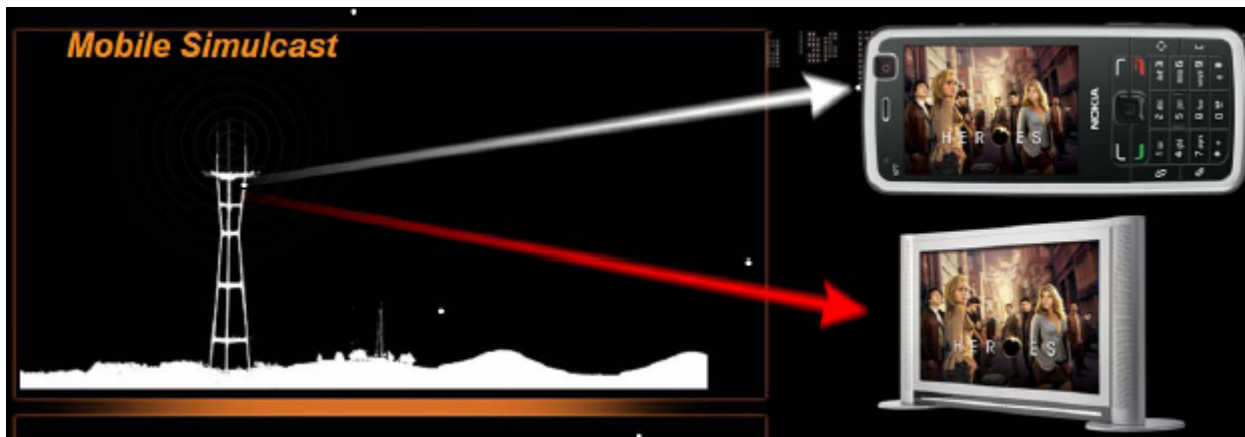

Source: MobiTV



ATSC-M/H Data Structure

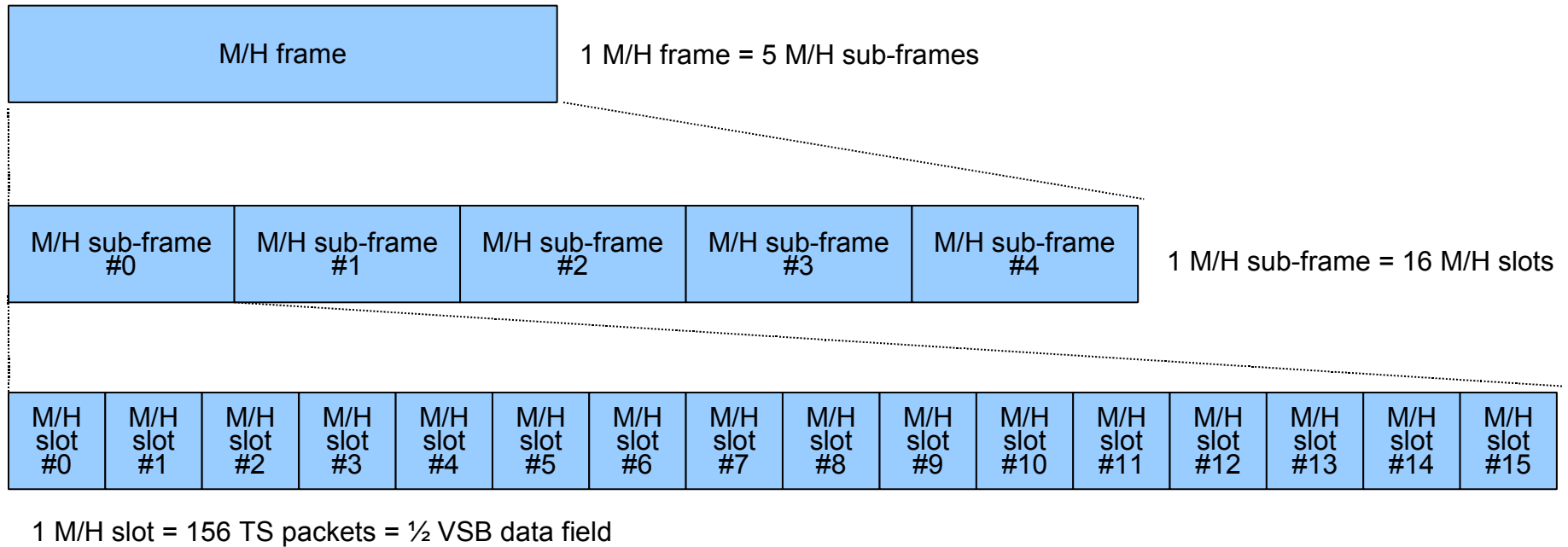

Burst Transmission

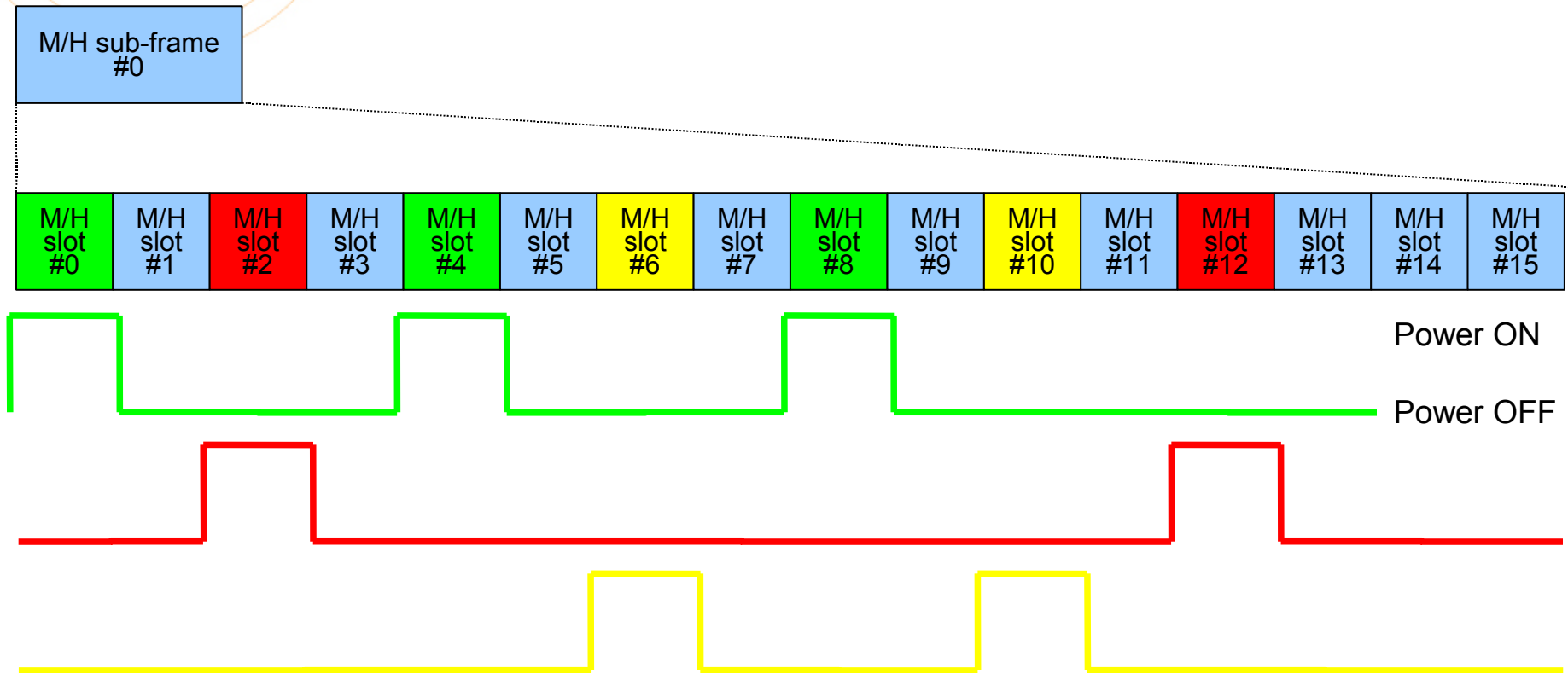

Legend:

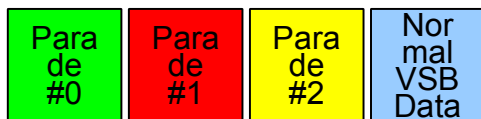

ATSC M/H Data Structure

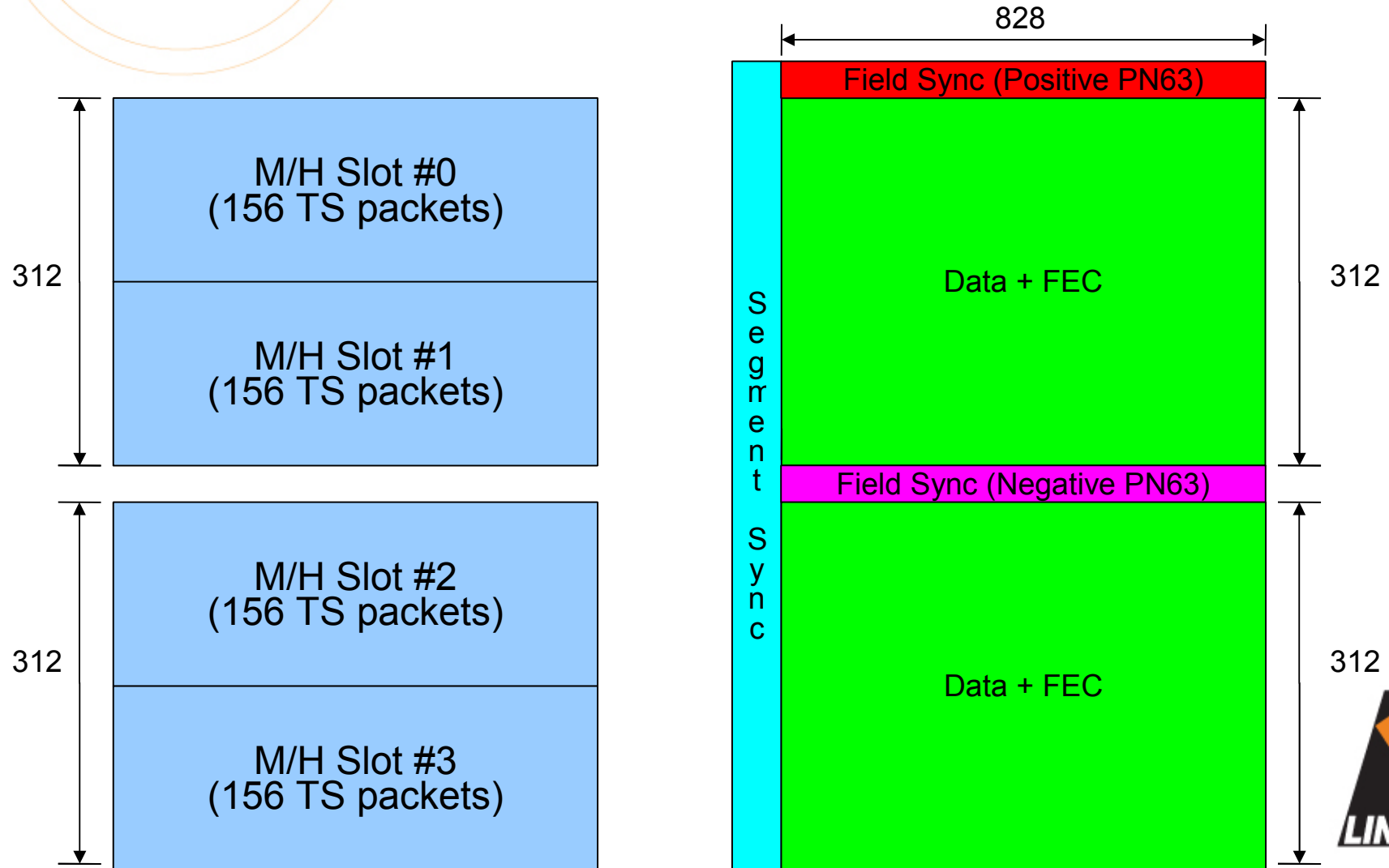

ATSC M/H Data Structure

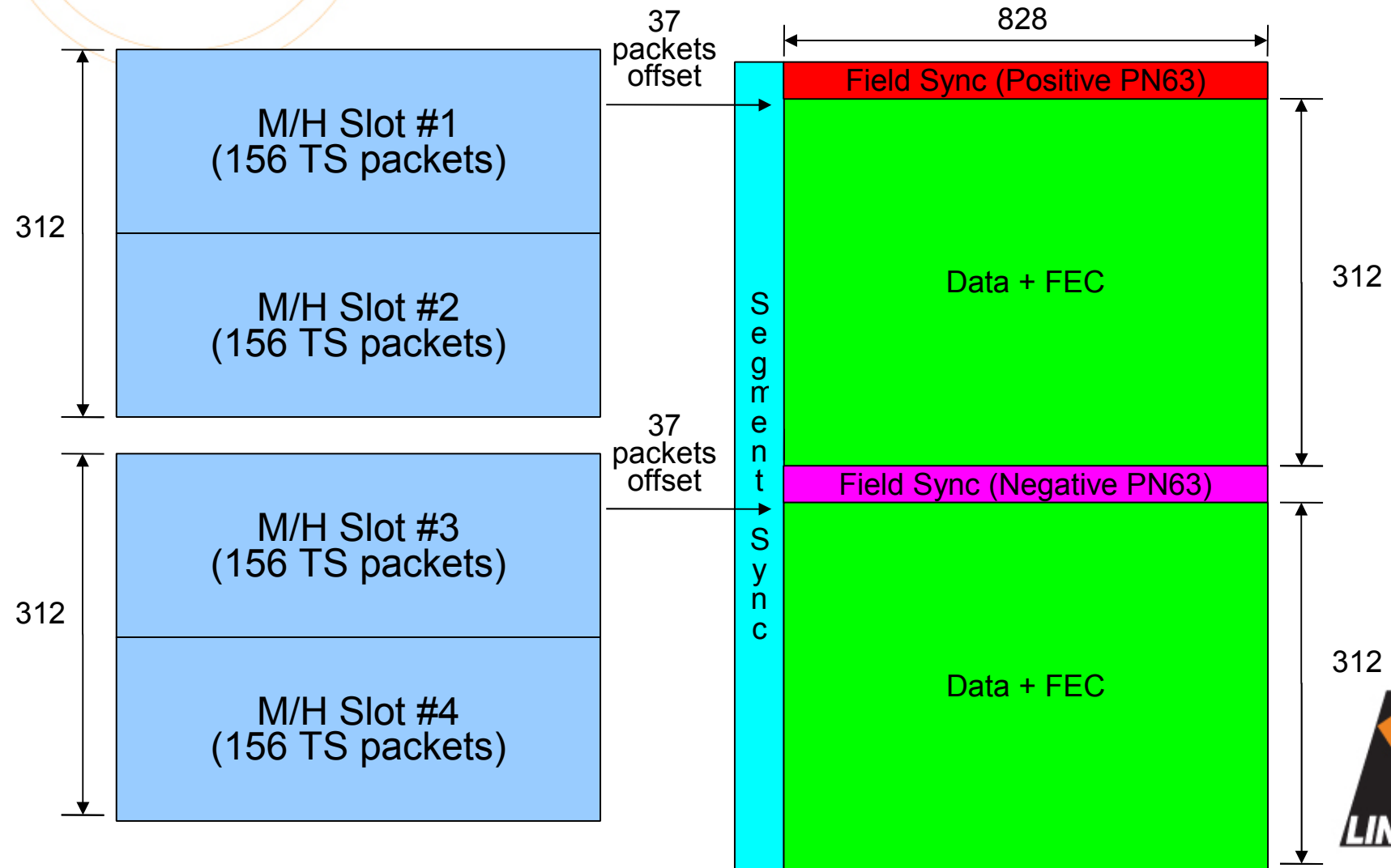

ATSC M/H Data Structure

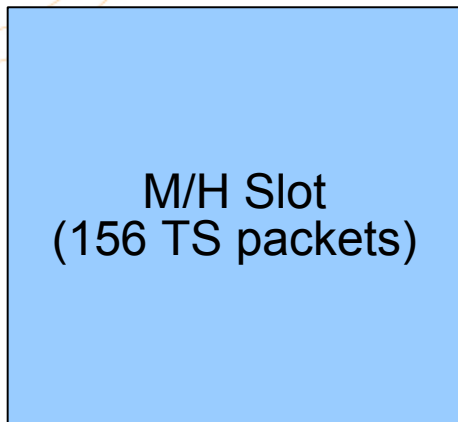

=

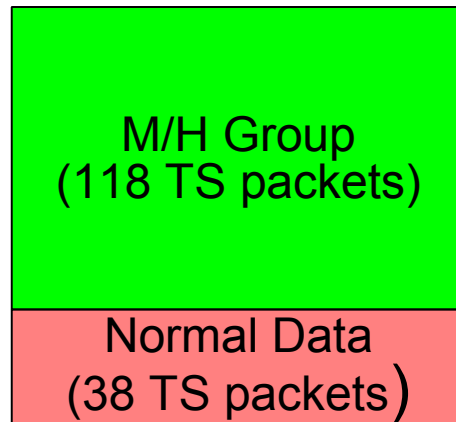

Half the
VSB Field
length
 $312/2 = 156$

or

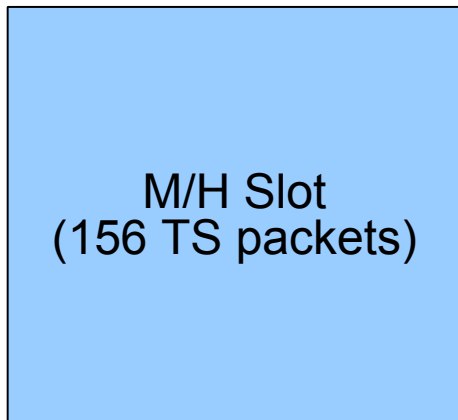

=

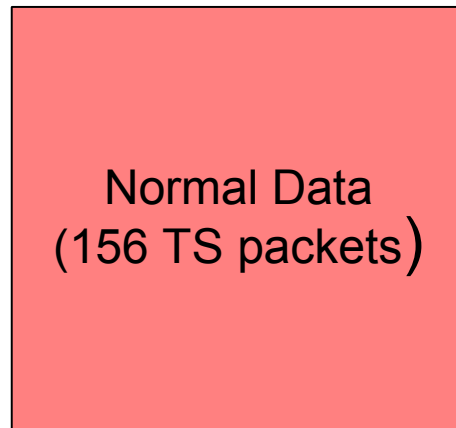

ATSC M/H Data Structure

156 Packets of Normal VSB Data + RS Parity Bytes Before Convolutional Interleaver

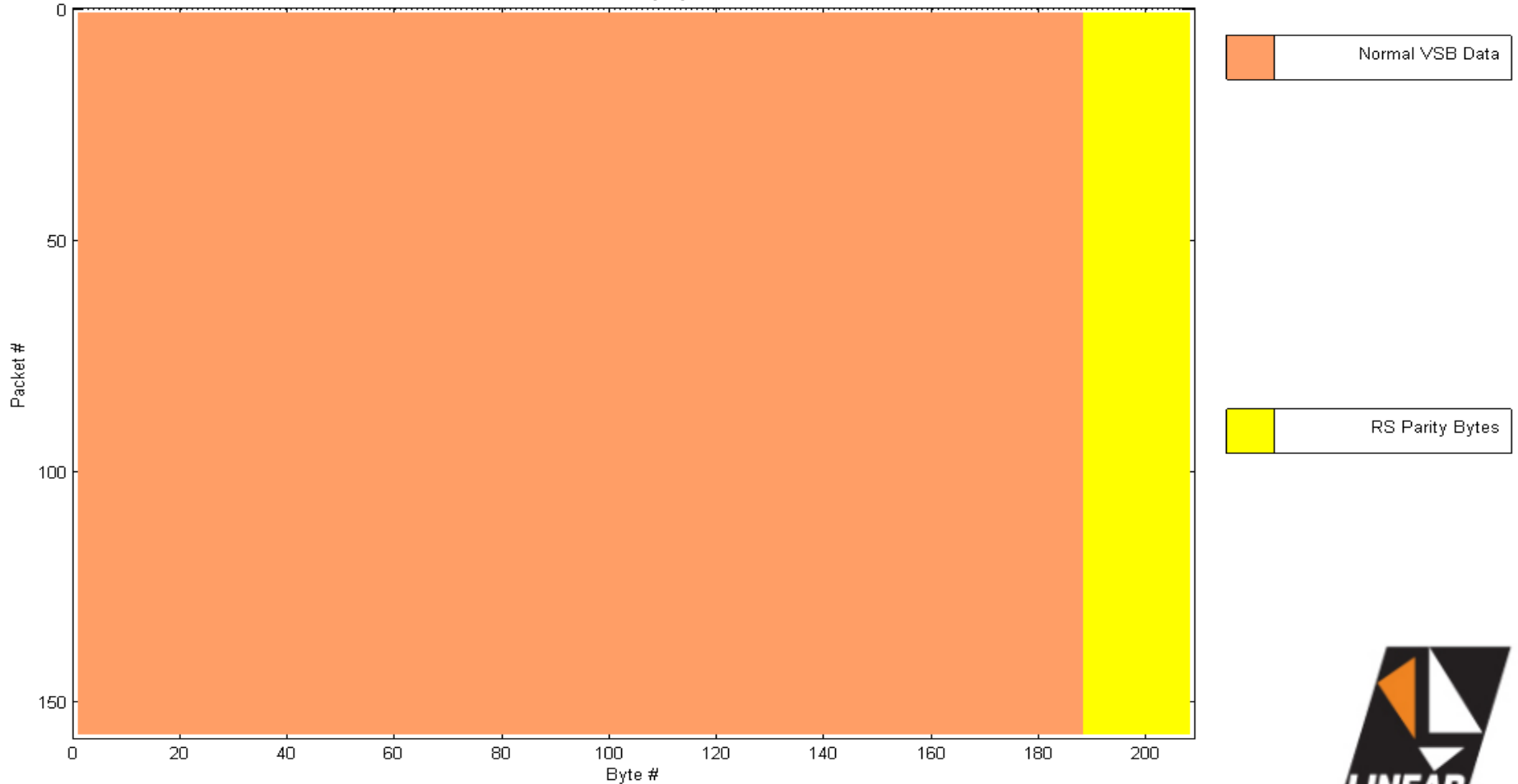

ATSC M/H Data Structure

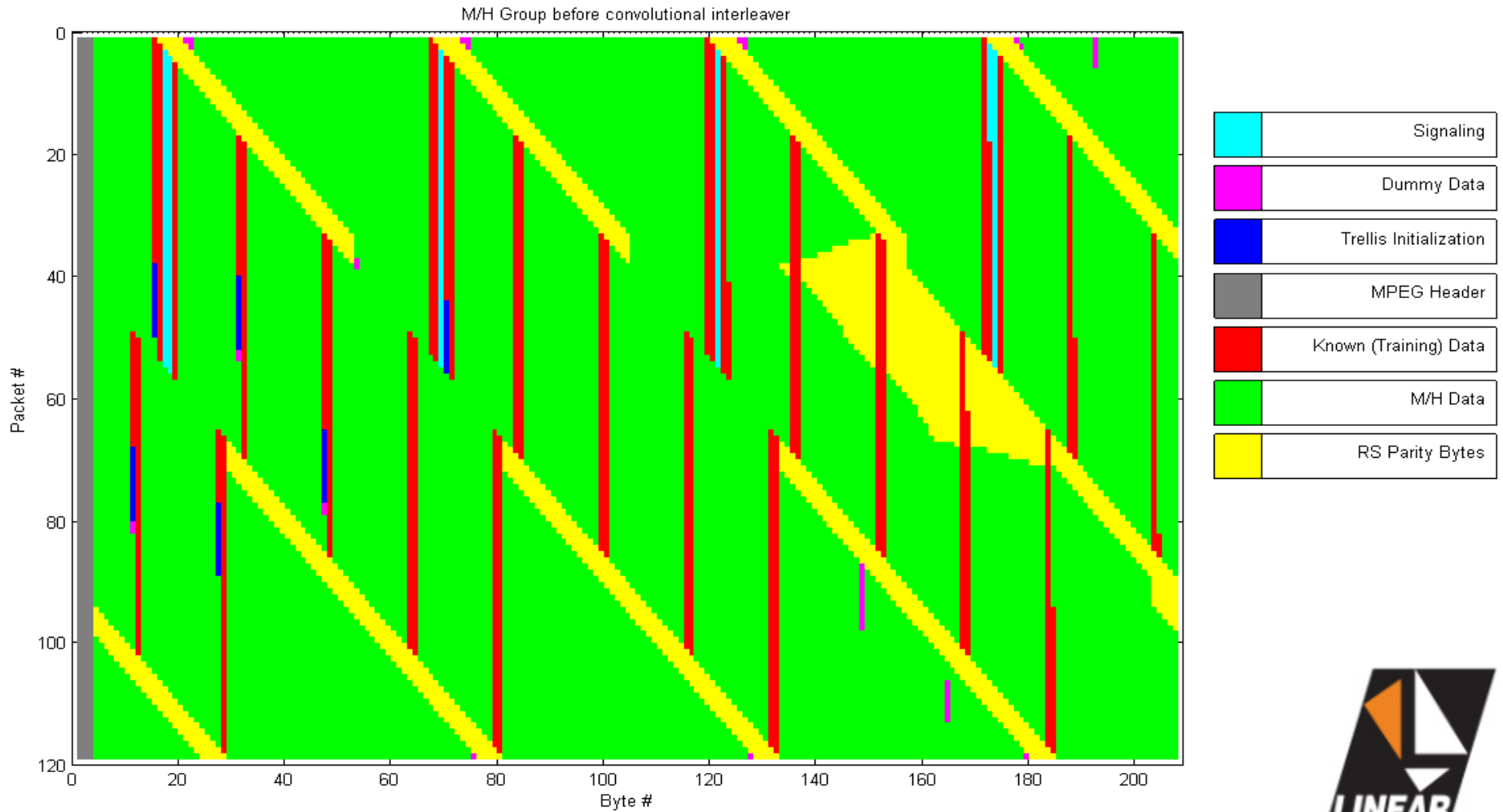

ATSC M/H Data Structure

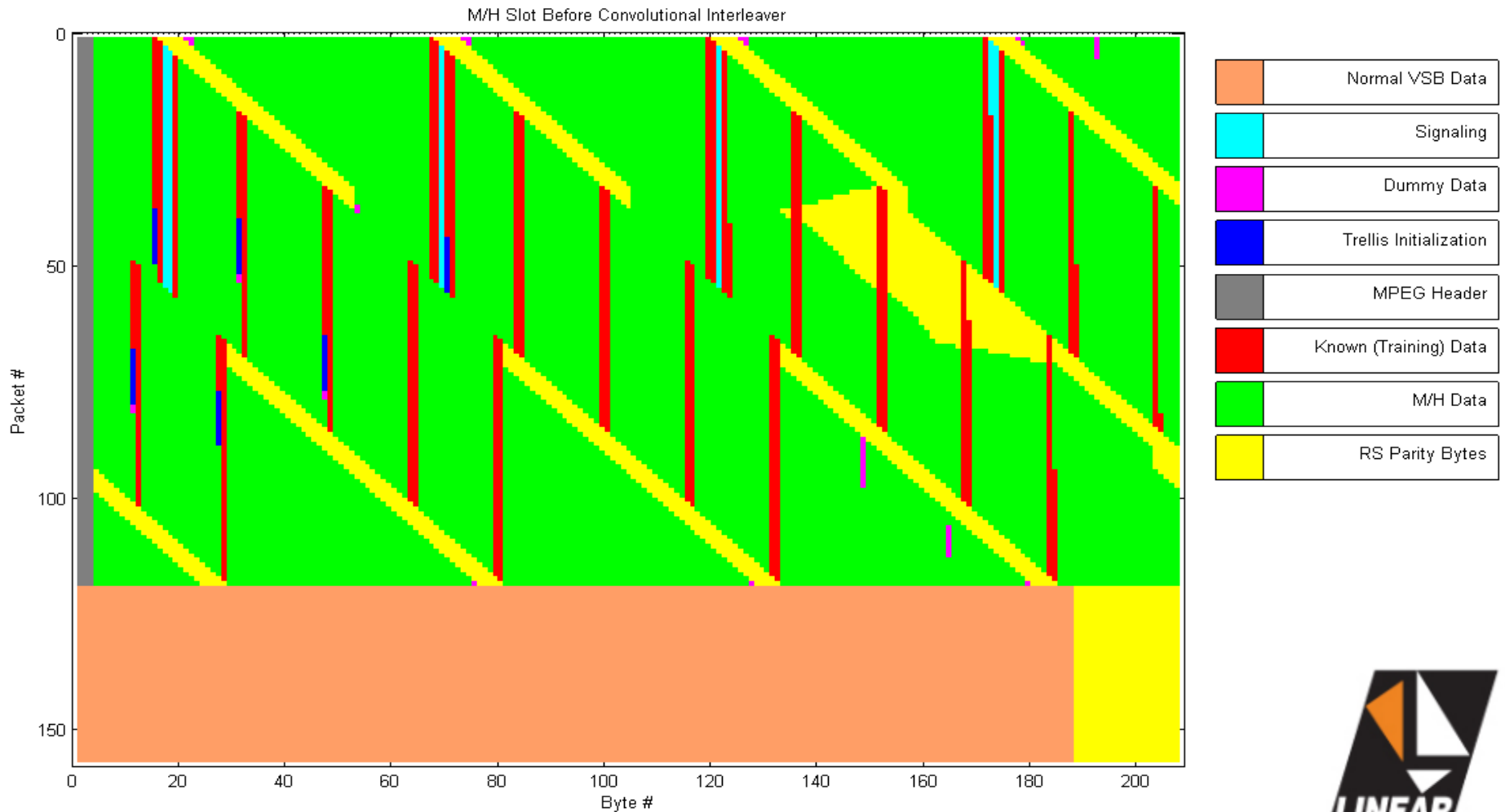

ATSC M/H Data Structure

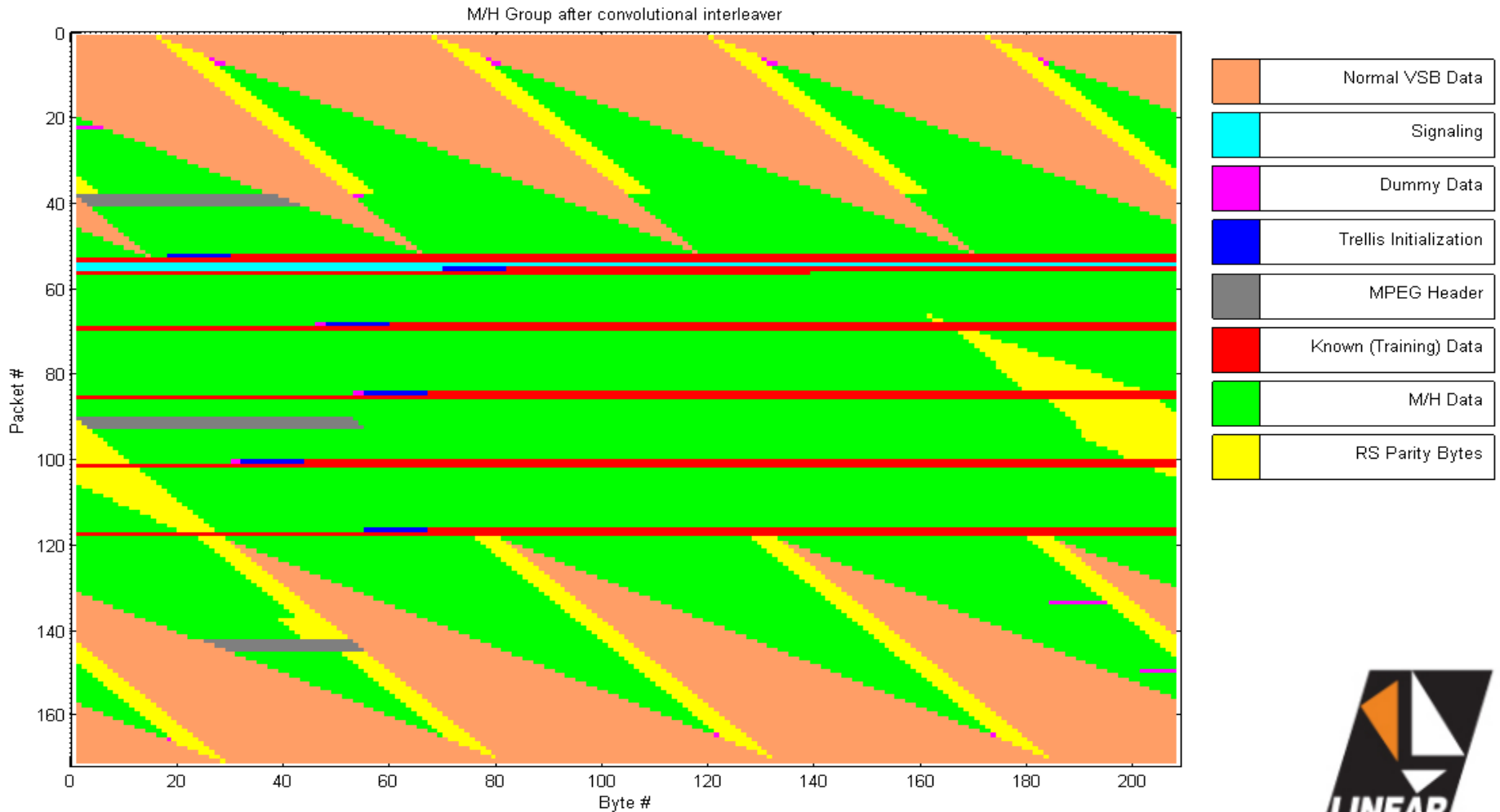

SFN over ATSC M/H Operation

- This solution uses the “Trellis Initialization Bytes” that already exists in the M/H system to make it SFN compatible.
- Based on a small software modification on both pre-processor (M/H Mux) and post-processor (M/H exciter).
- It means you can't go SFN without going mobile.



SFN over ATSC M/H System Diagram

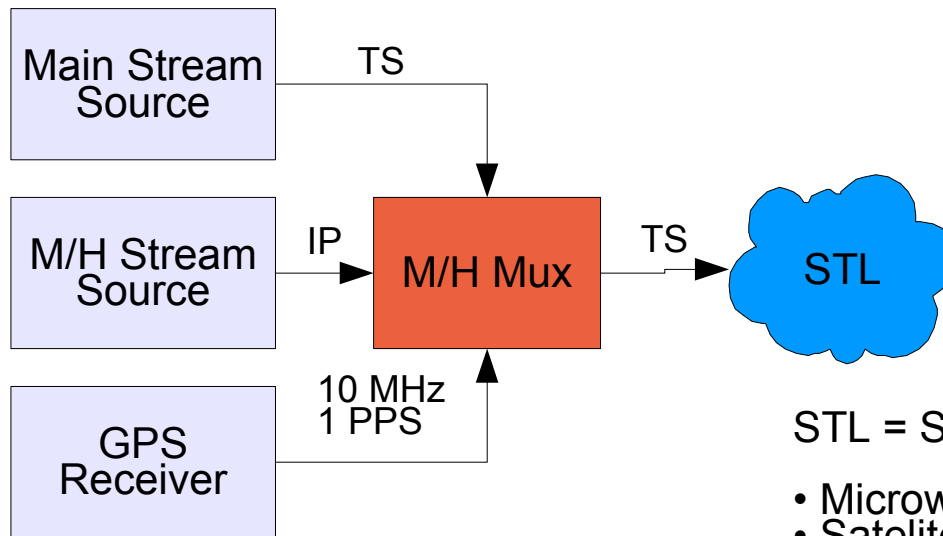

STL = Studio to Transmitter Link:

- Microwave
- Satellite
- Fiber



SFN over ATSC M/H System Diagram

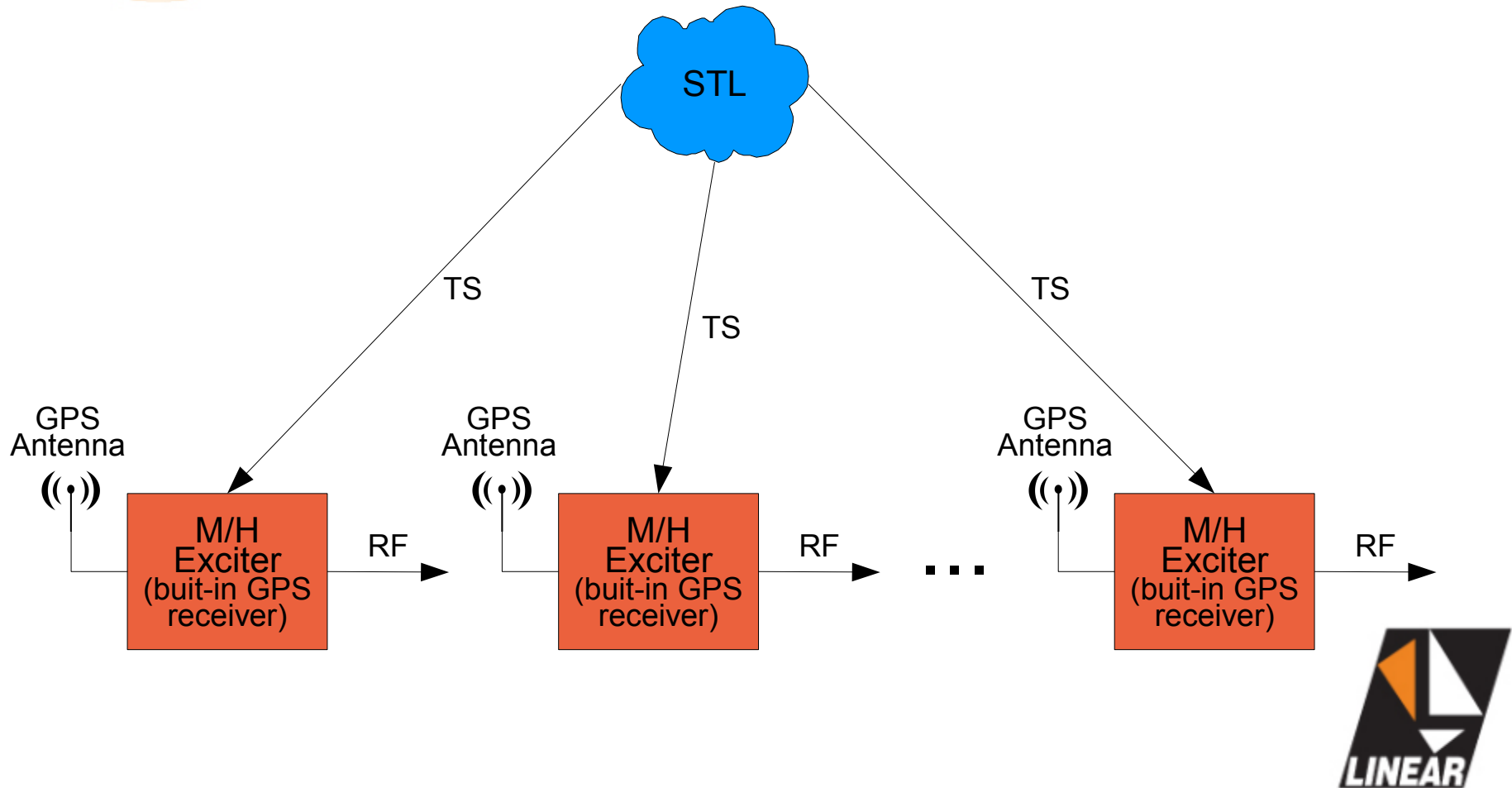

Measurements

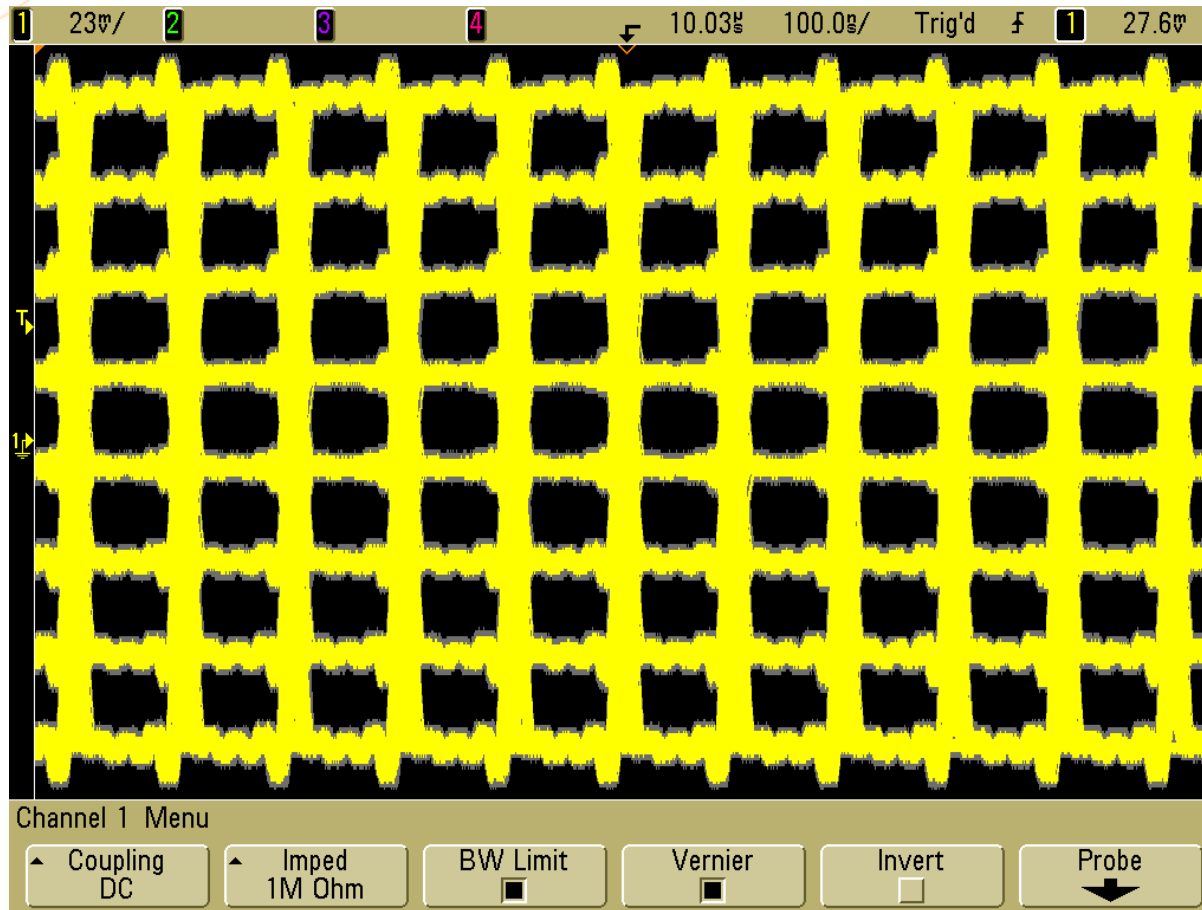

8-level modulating symbols



Measurements

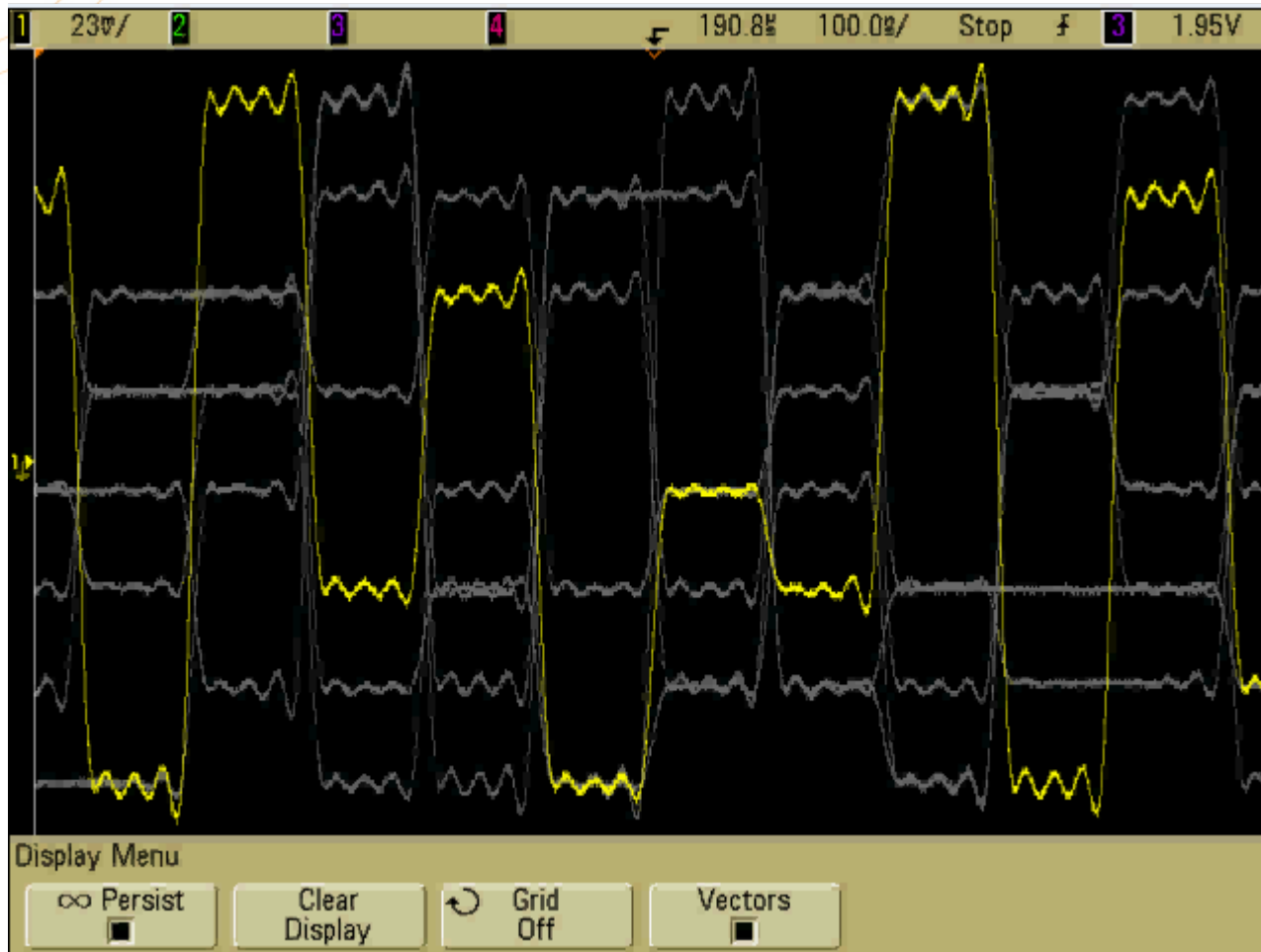

8-level random symbols



Measurements

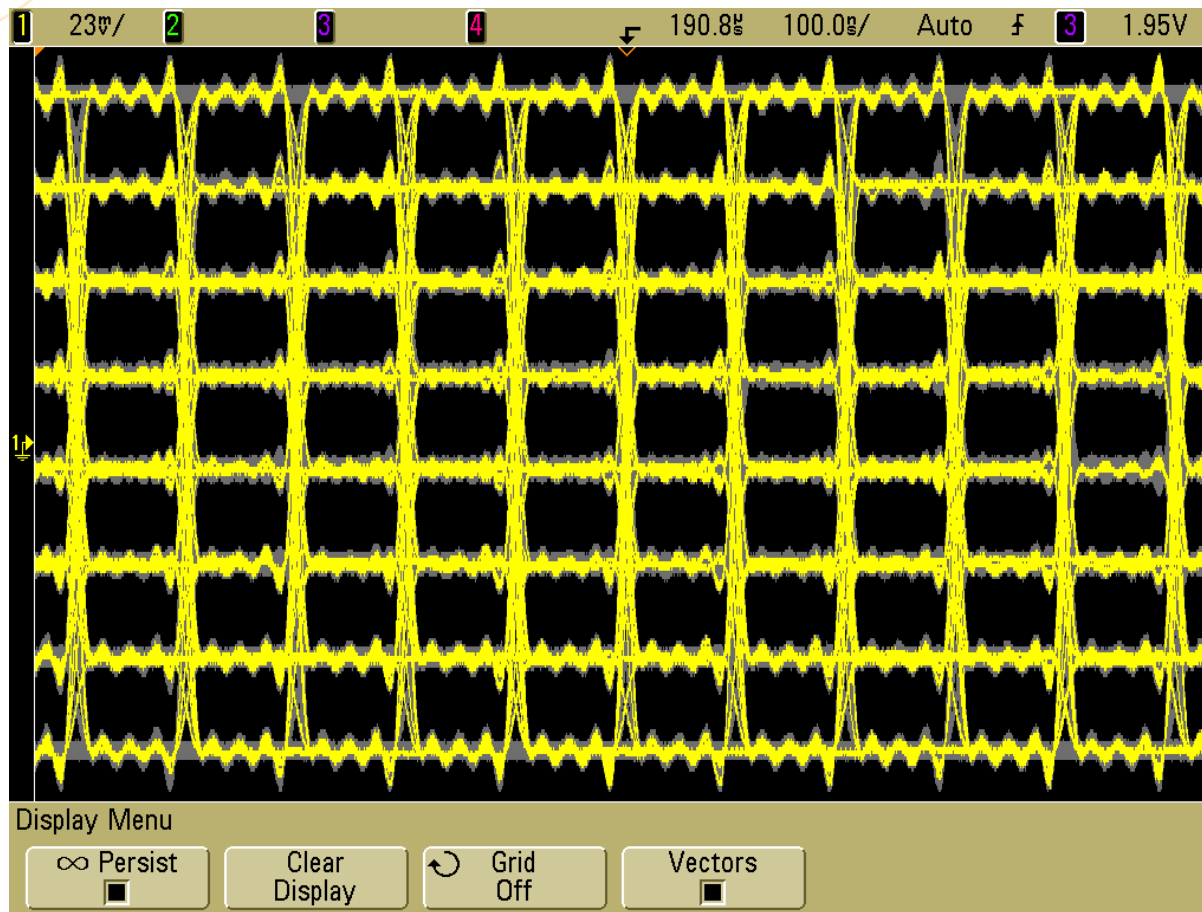

8-level modulating symbols



Measurements



unsynchronized symbols



Measurements

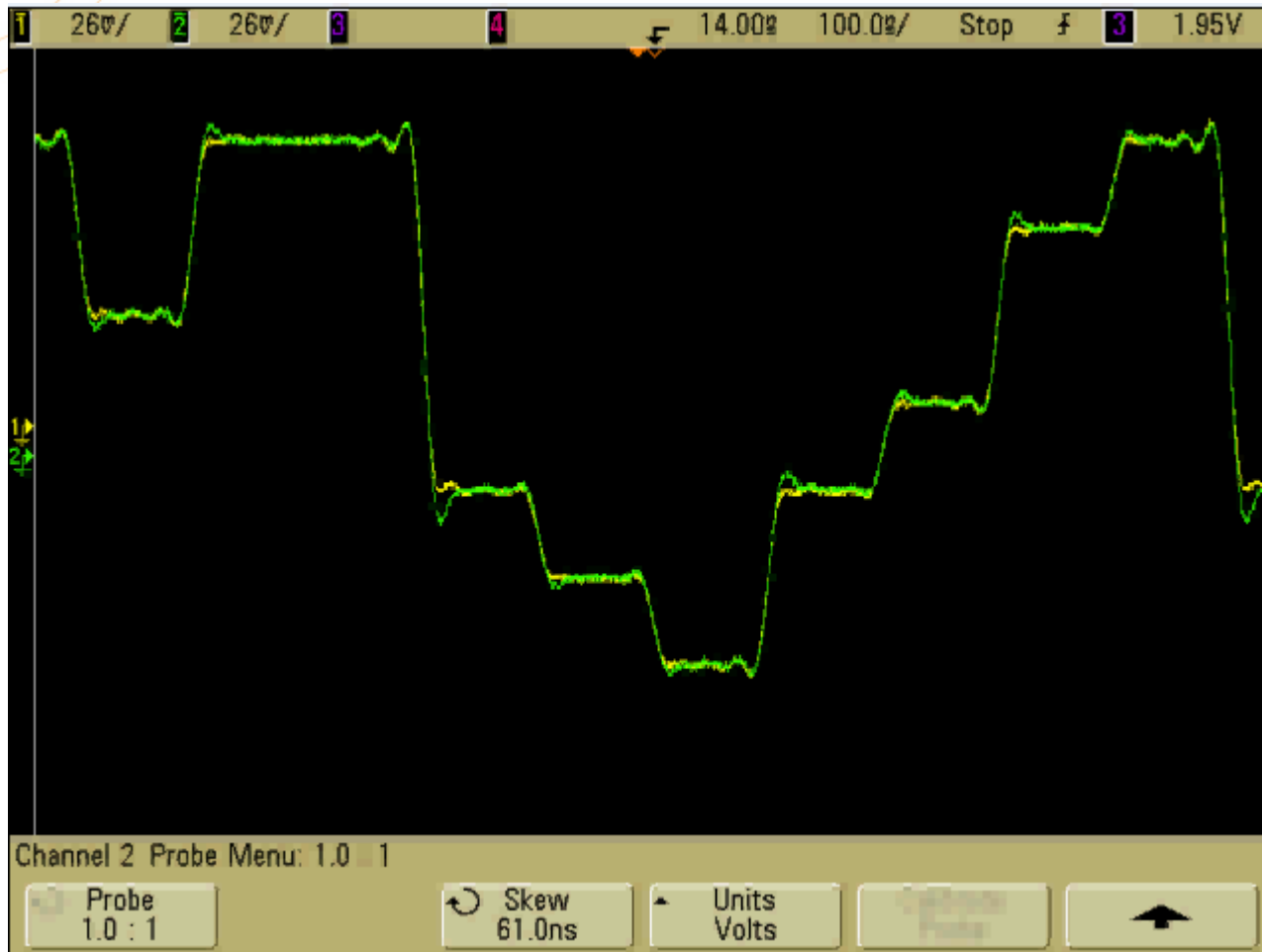

synchronized symbols



Measurements

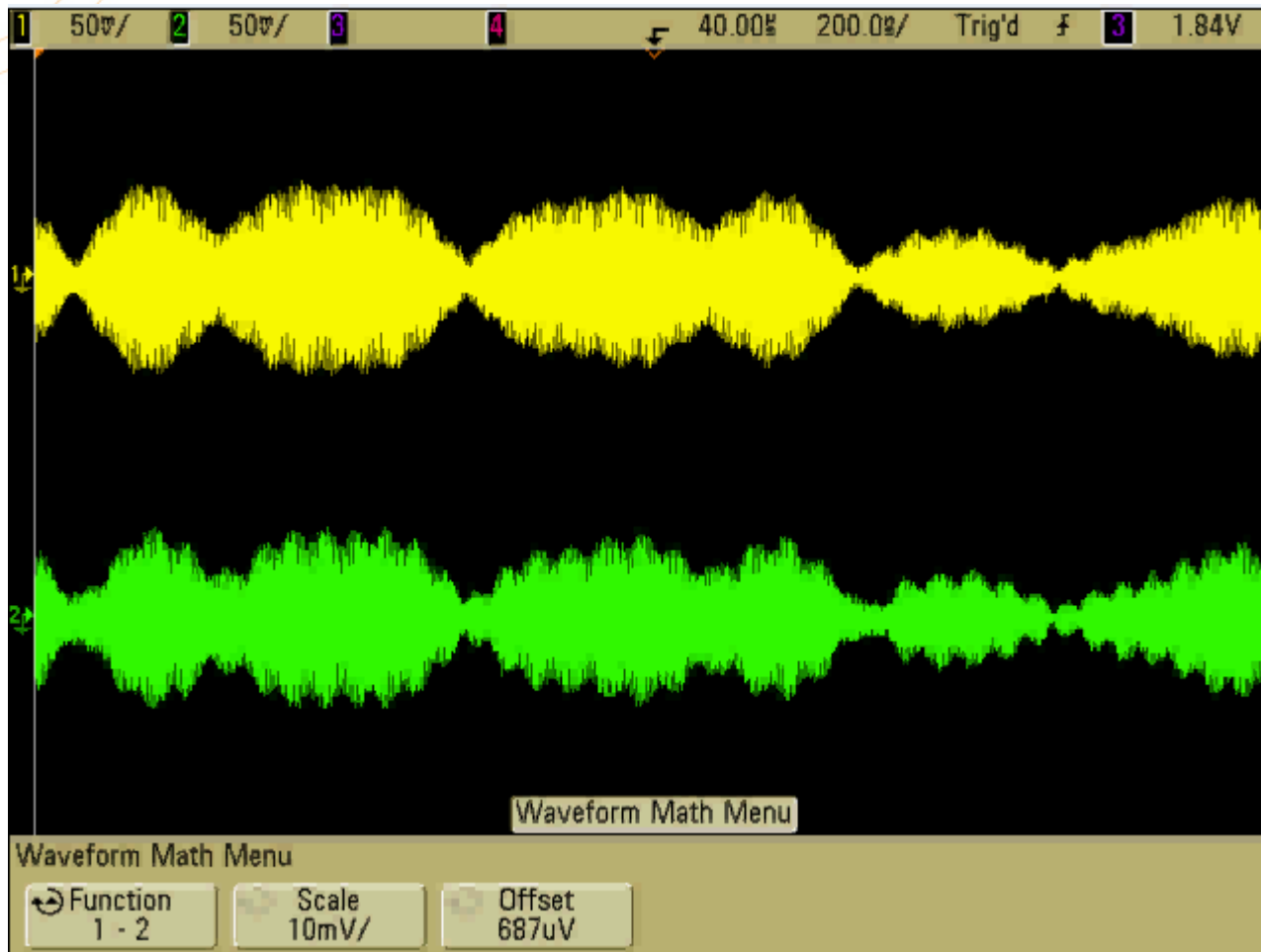

synchronized RF carriers



Multipath environment



Ghost
Pattern

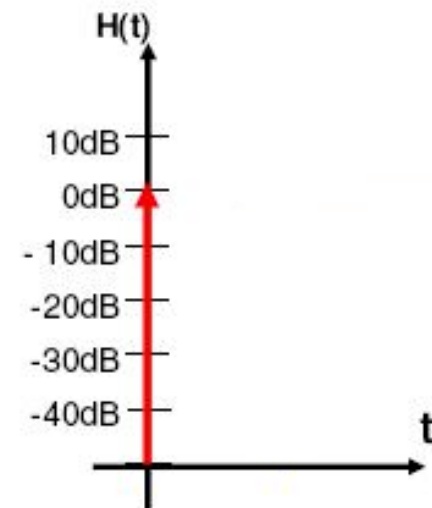

Multipath environment

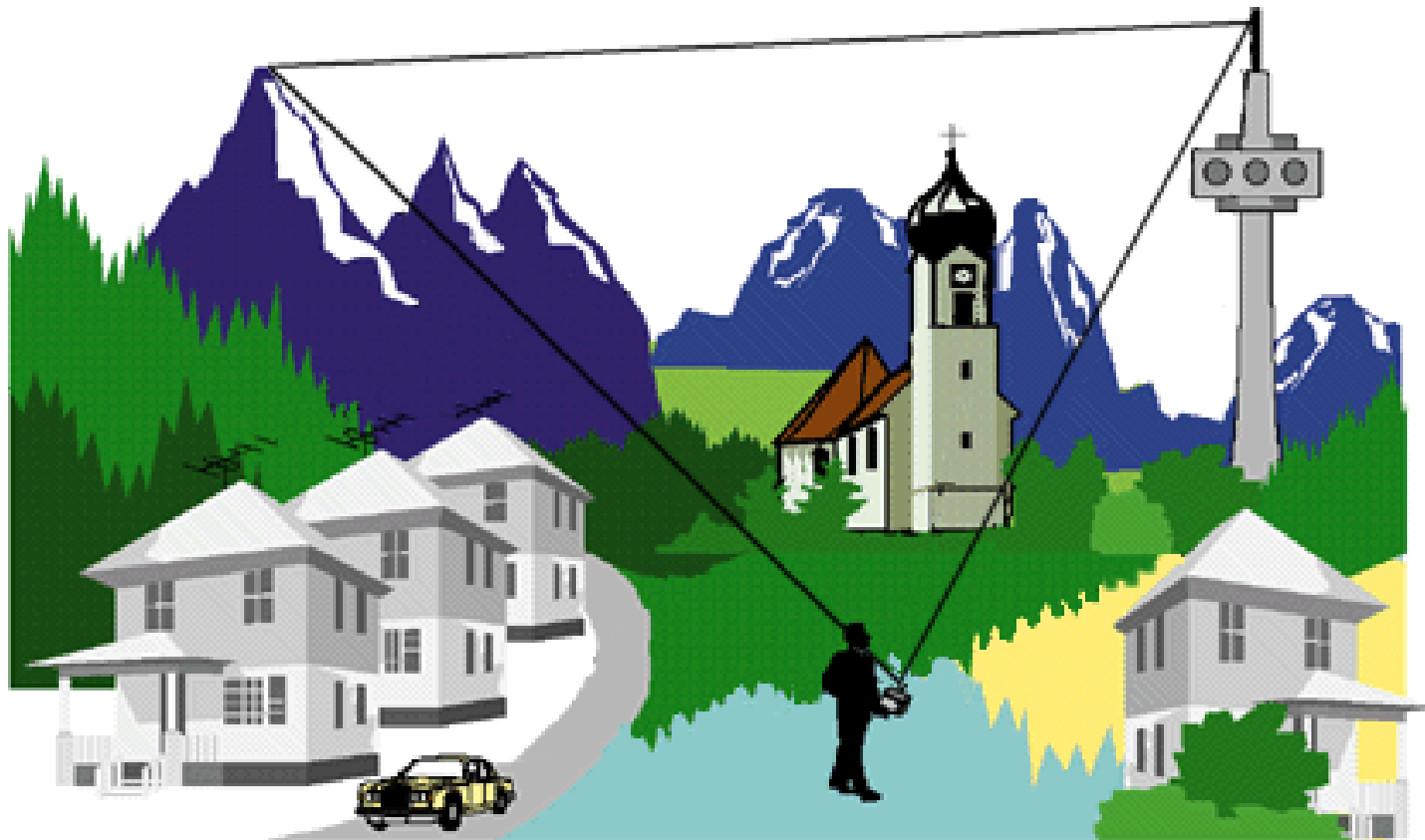

Ghost Pattern

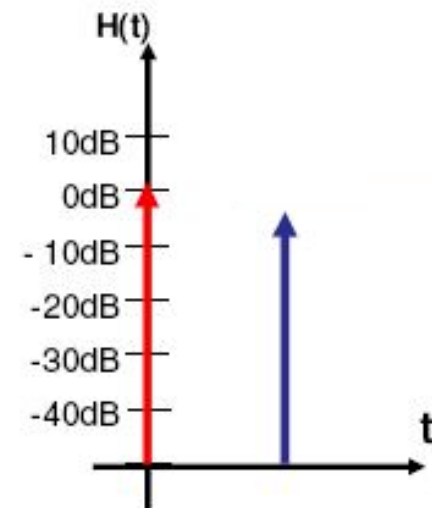

SFN environment



Ghost
Pattern

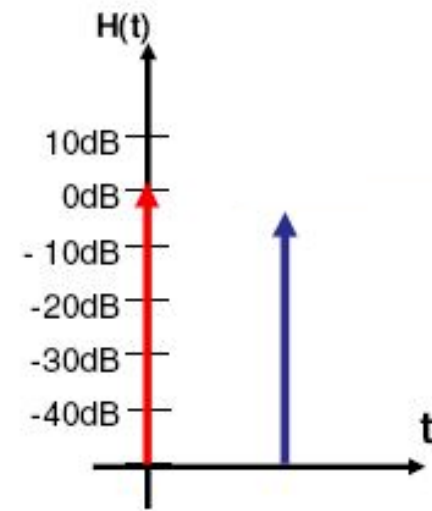

SFN environment

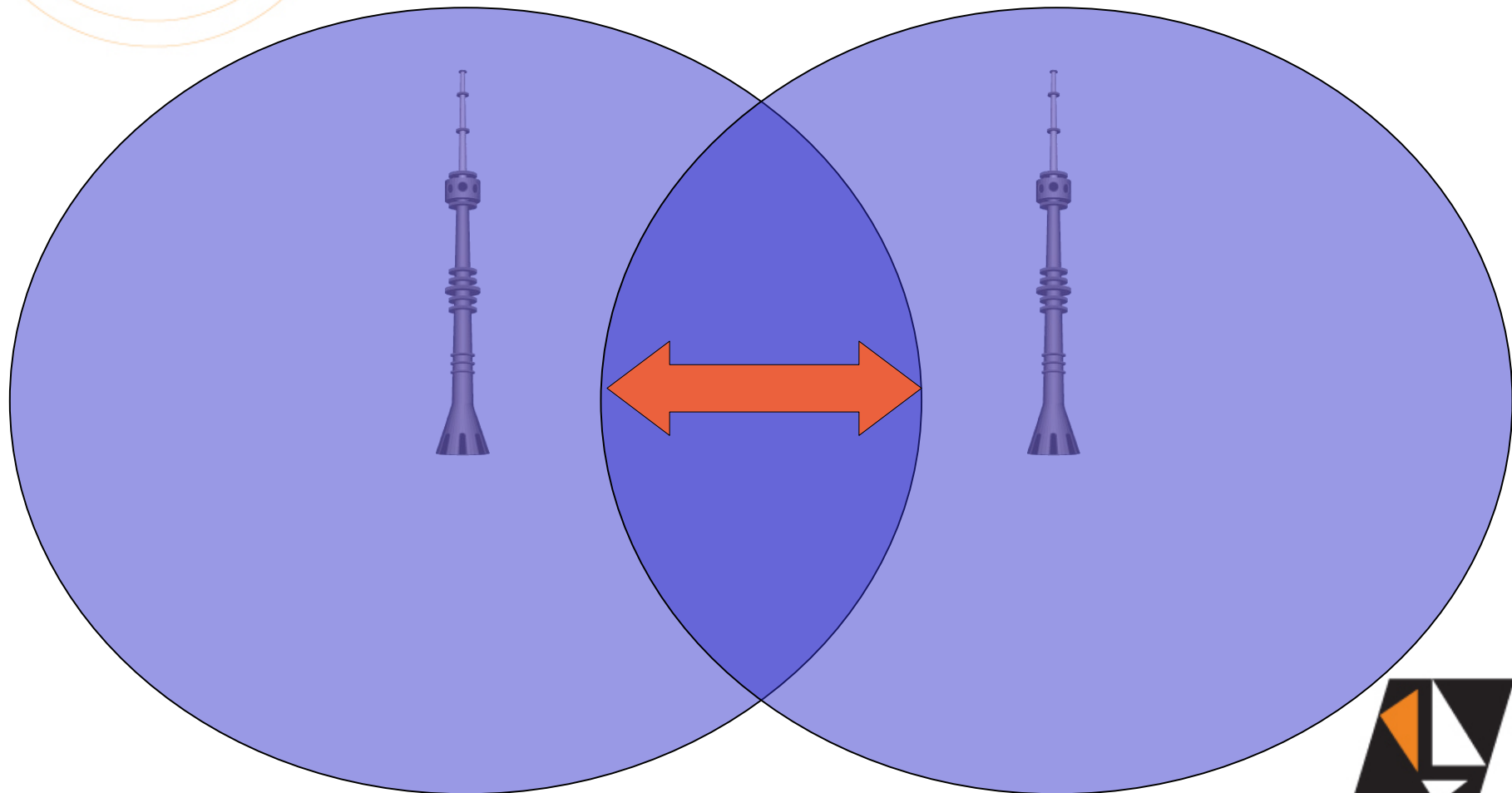

Overlapping Area



SFN delay adjustment

Two RF Carriers @ time domain

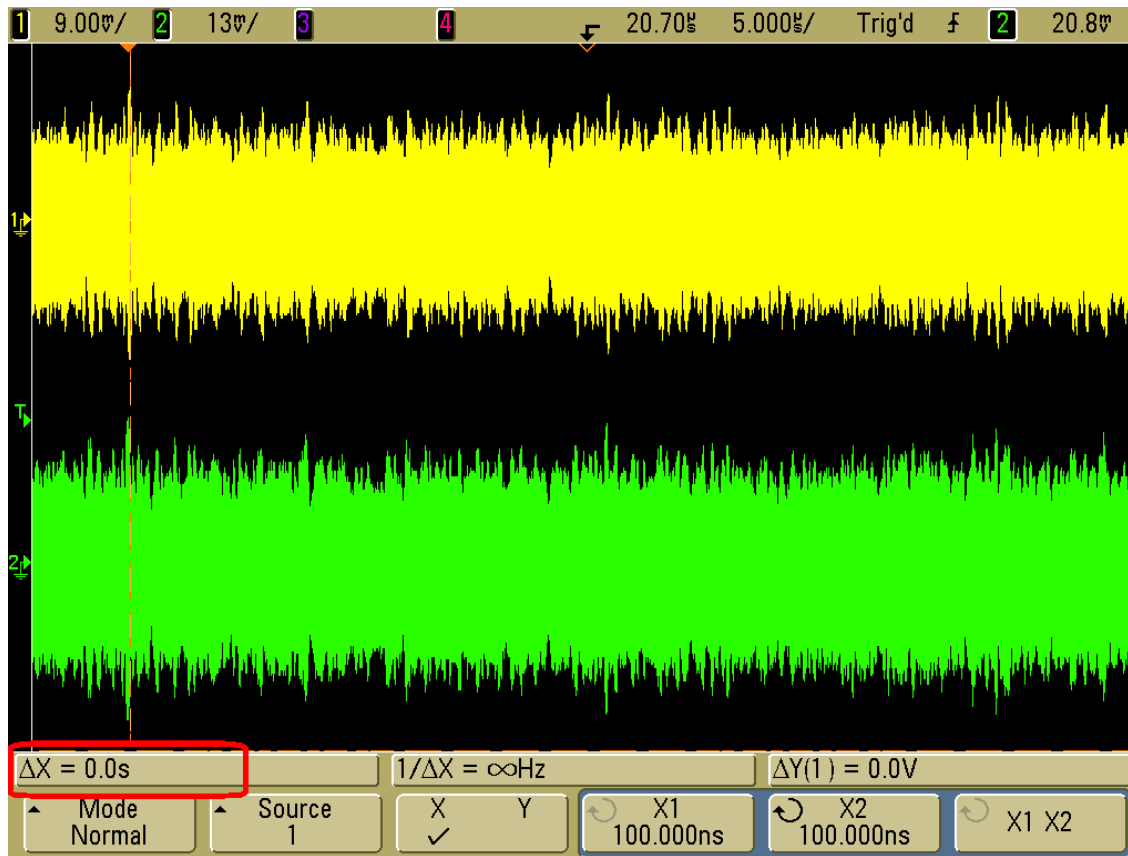

Combined RF Carriers @ Ghost Pattern

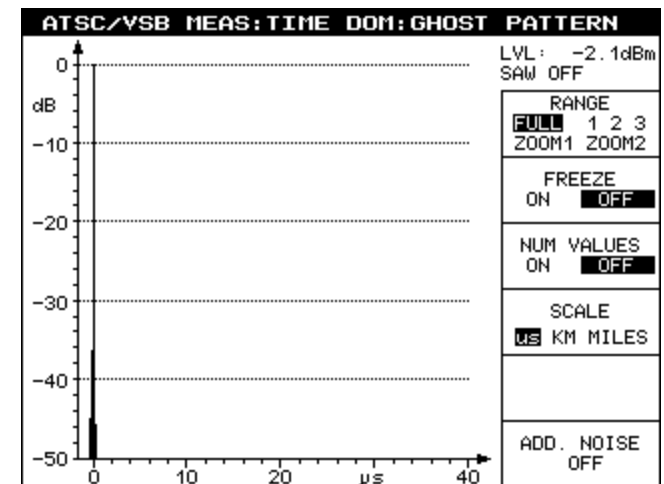

Delay = 0 μs



SFN delay adjustment

Two RF Carriers @ time domain

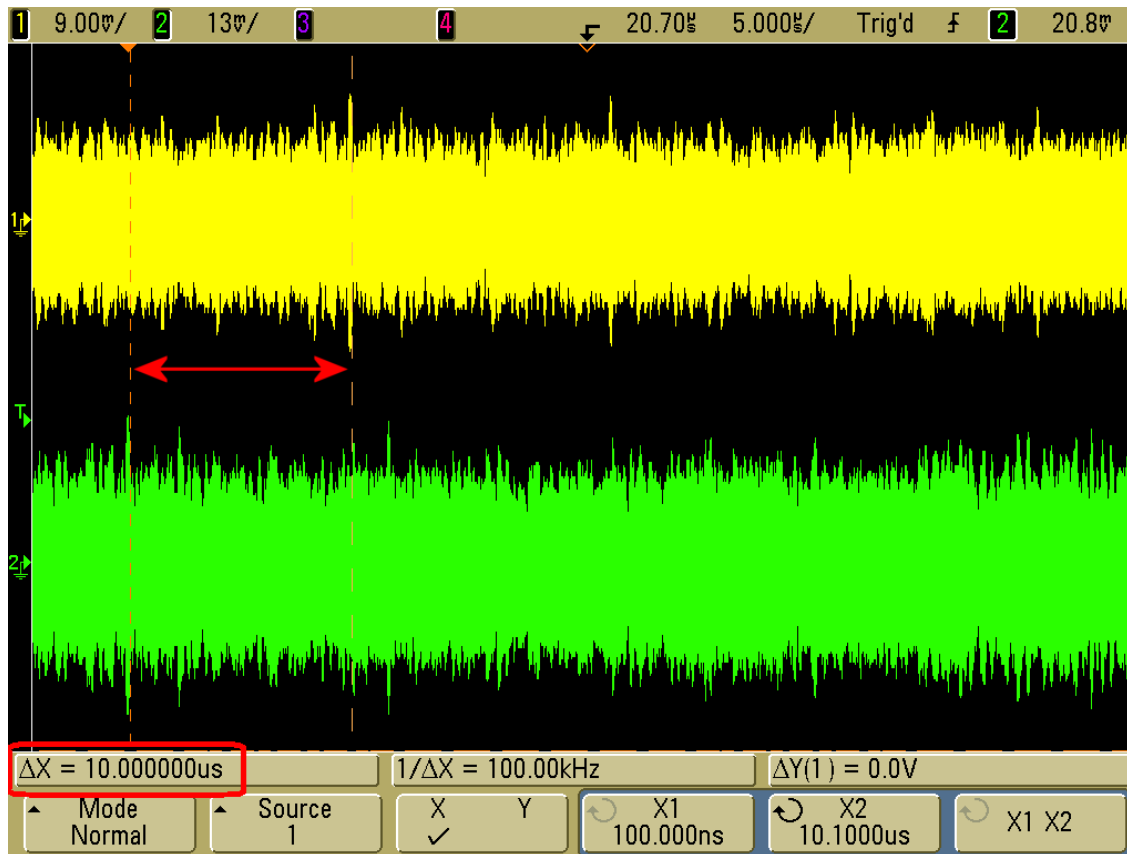

Combined RF Carriers @ Ghost Pattern

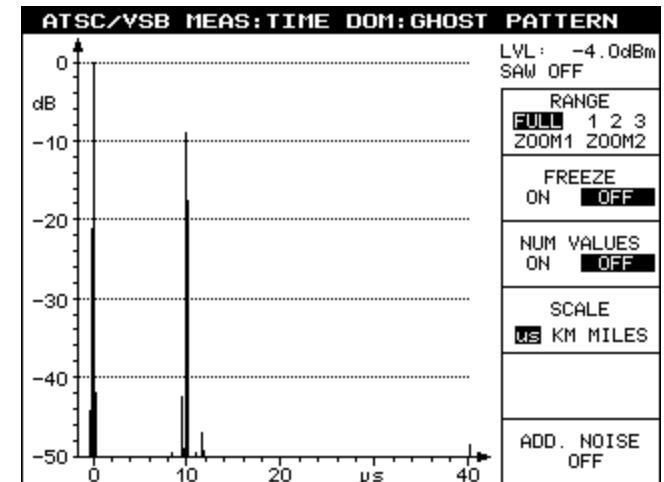

Delay = 10 μs



SFN delay adjustment

Two RF Carriers @ time domain

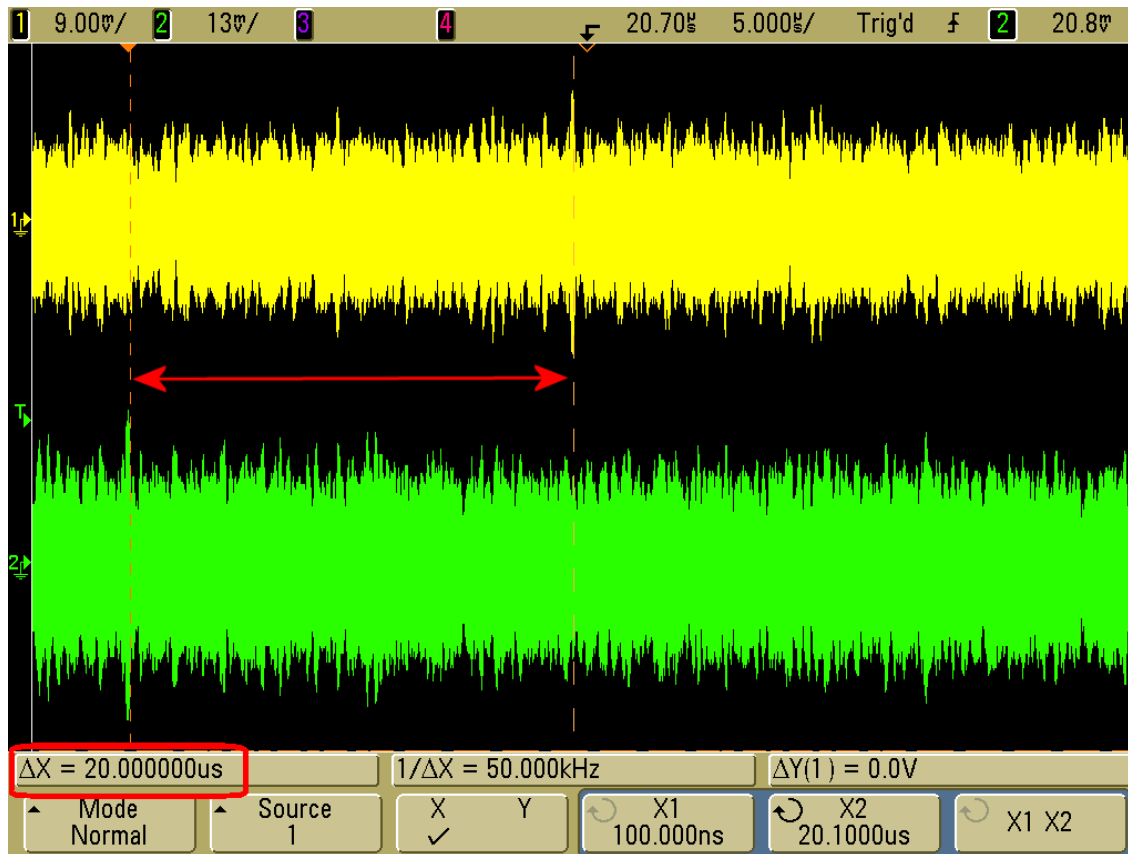

Combined RF Carriers @ Ghost Pattern

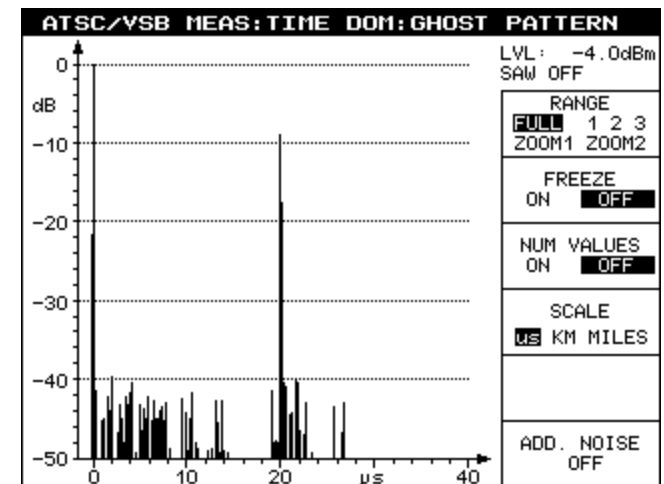

Delay = 20 μs



SFN delay adjustment

Two RF Carriers @ time domain

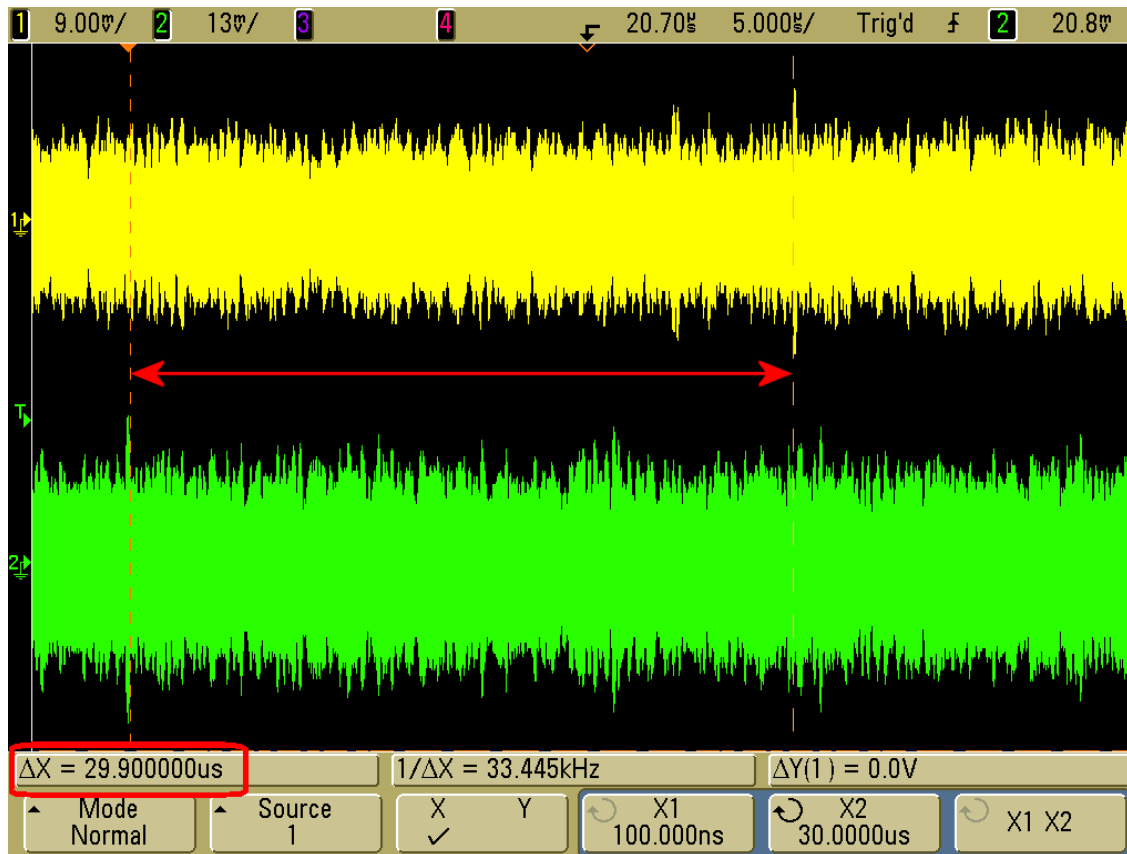

Combined RF Carriers @ Ghost Pattern

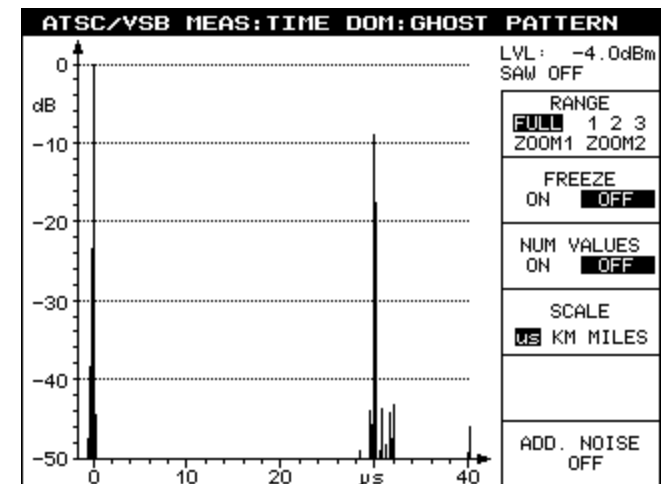

Delay = 30 μs



SFN delay adjustment

Two RF Carriers @ time domain

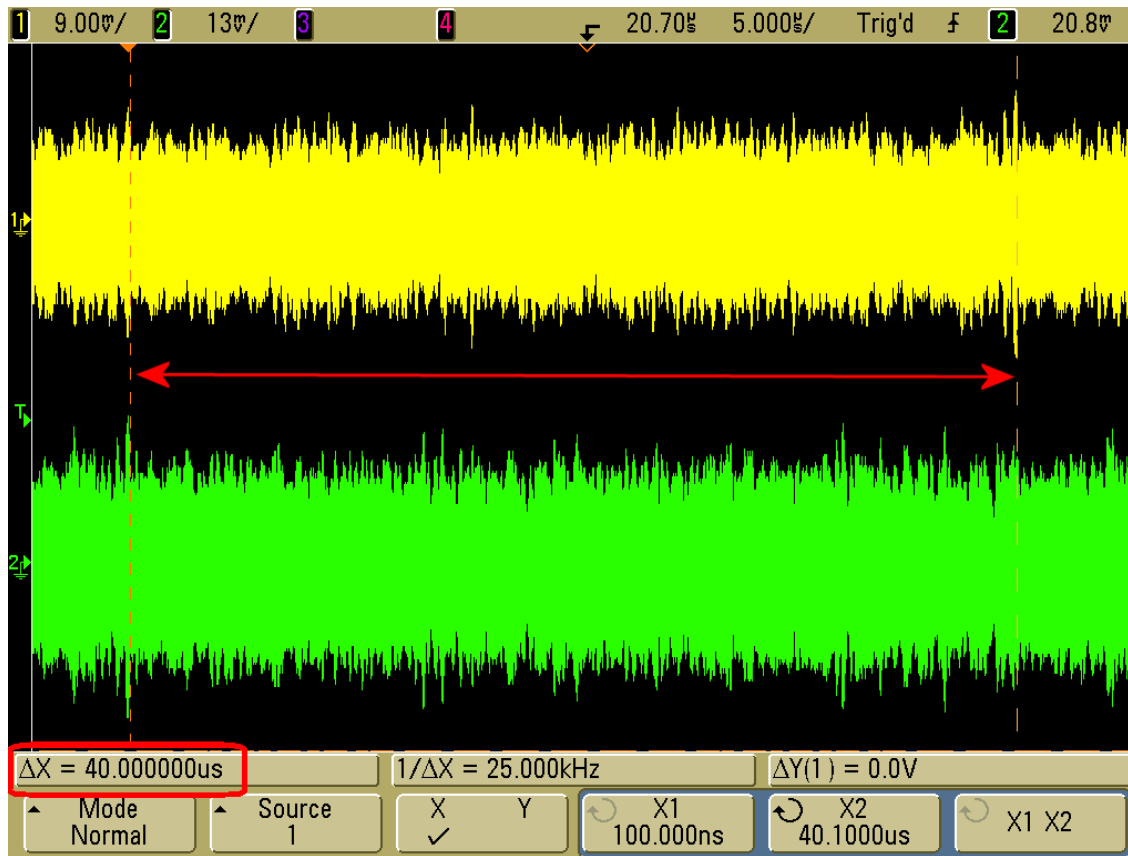

Combined RF Carriers @ Ghost Pattern

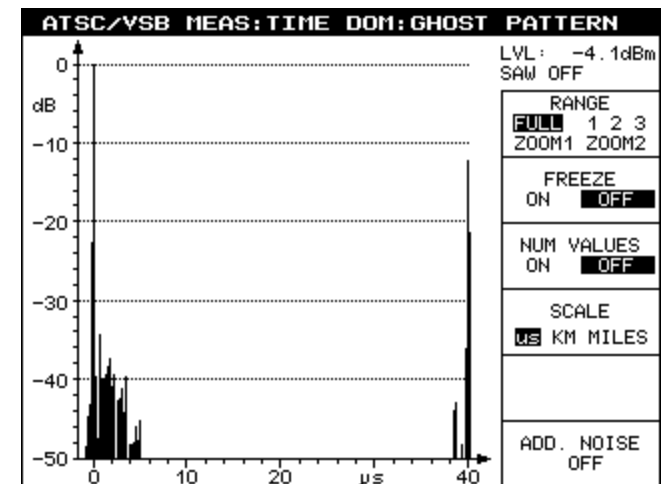

Delay = 40 μs



ATSC DTV receiver performance

- DTV receivers can be categorized into four groups:
 - Built before 1998 (Rx C);
 - Built in 1998 to 1999 (Rx F);
 - Built in 2000 to 2004 (Rx G);
 - Next generation Receivers later 2005 (Rx V).



ATSC DTV receiver performance

Comparison Between Different Generations of Rx's

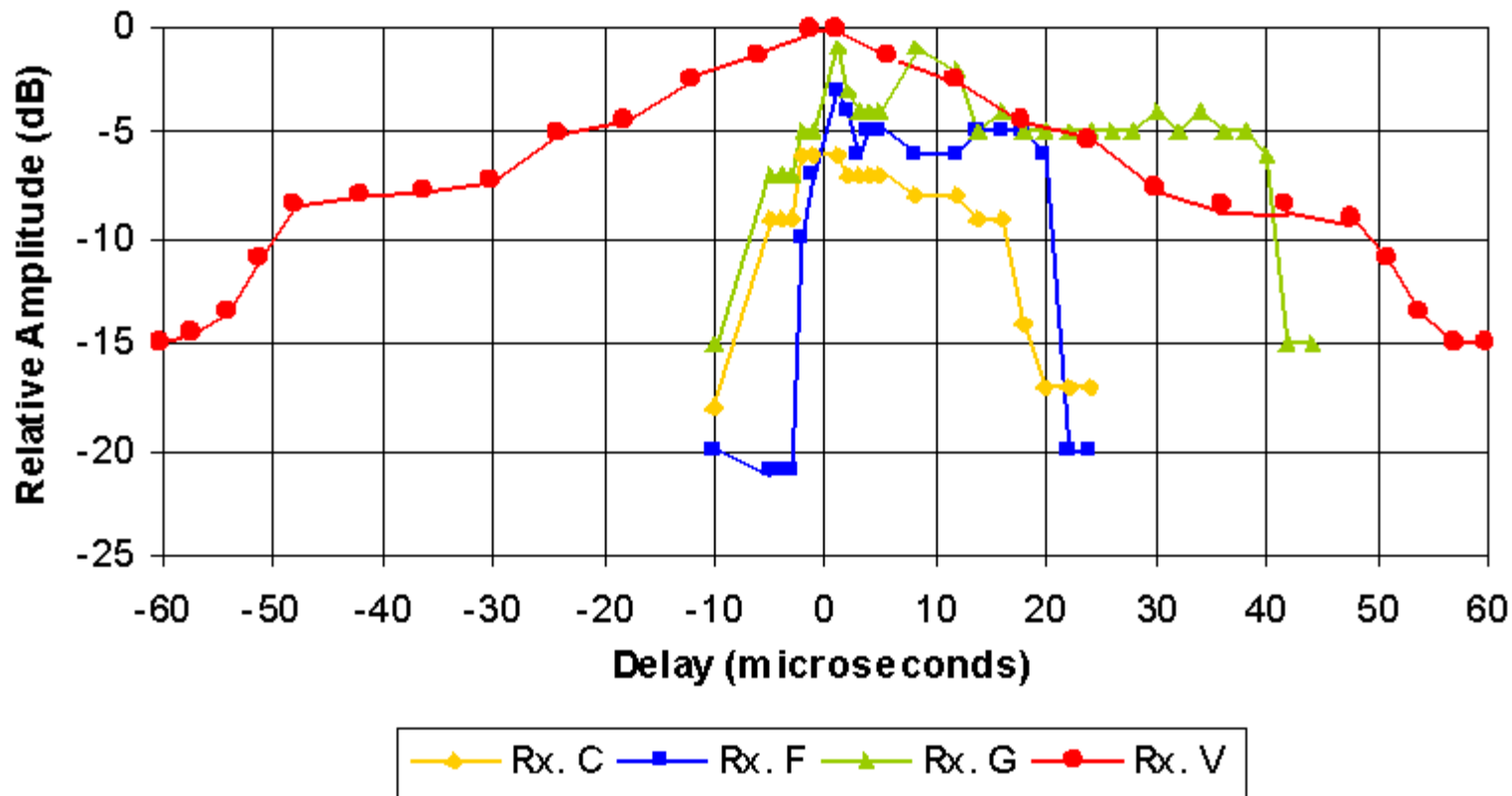

ATSC DTV receiver performance

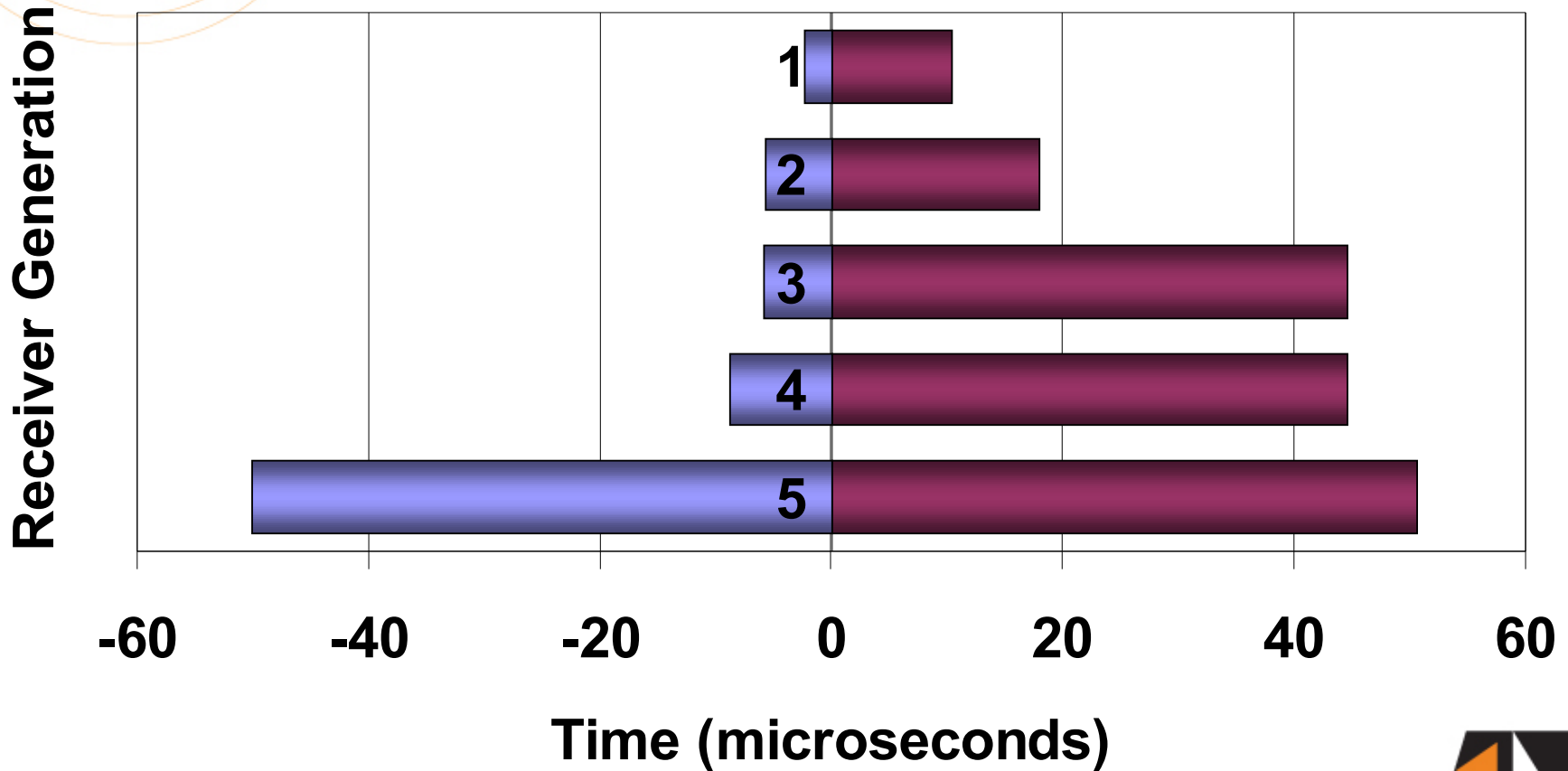

source: Zenith



Maximum overlapping area vs receiver performance

<i>Receiver Generation</i>	<i>Equalizer Length [μs]</i>	<i>Equiv. Overlapping Distance [km]</i>	<i>Equiv. Overlapping Distance [miles]</i>
1	10.5	3.15	1.96
2	18	5.4	3.35
3	44.6	13.37	8.31
4	44.6	13.37	8.31
5	50.6	15.17	9.43

$$c = 299,792,458 \text{ m/s}$$



SFN over ATSC M/H Characteristics

- Intrinsic Bit Error Rate due to Trellis Initialization.

ATSC/VSB MEASURE			
CENTER FREQ 587.00 MHz	CHANNEL 33	ATTEN : 35 dB -7.2 dBm	
SET CENTER FREQ	587.0000000 MHz	CONSTELL DIAGRAM...	
SET PILOT FREQ	584.3094406 MHz		
CALC PILOT FREQ	584.3106836 MHz		
PILOT FREQ OFFSET	1243.0 Hz	FREQUENCY DOMAIN...	
SYMBOL RATE OFFSET	22.8 Hz		
MODULATION	8VSB	TIME DOMAIN...	
MER (REAL,RMS)	44.2 dB		
MER (REAL,RMS)	0.61 %		
BER BEFORE RS	0.0E-8 (20/100)	VSB PARA- METERS...	
BER AFTER RS	0.0E-7 (16/100)		
SEG ERR RATIO	0.0E-5 (16/100)		
SEG ERR / s	00000	RESET BER	
TS BIT RATE 19.393 Mbit/s			
SAW:OFF		ADD. NOISE OFF	

SFN mode OFF

ATSC/VSB MEASURE			
CENTER FREQ 587.00 MHz	CHANNEL 33	ATTEN : 35 dB -7.1 dBm	
SET CENTER FREQ	587.0000000 MHz	CONSTELL DIAGRAM...	
SET PILOT FREQ	584.3094406 MHz		
CALC PILOT FREQ	584.3107034 MHz		
PILOT FREQ OFFSET	1262.8 Hz	FREQUENCY DOMAIN...	
SYMBOL RATE OFFSET	23.2 Hz		
MODULATION	8VSB	TIME DOMAIN...	
MER (REAL,RMS)	43.6 dB		
MER (REAL,RMS)	0.65 %		
BER BEFORE RS	2.2E-6 (10/10)	VSB PARA- METERS...	
BER AFTER RS	0.0E-7 (37/100)		
SEG ERR RATIO	0.0E-5 (37/100)		
SEG ERR / s	00000	RESET BER	
TS BIT RATE 19.393 Mbit/s			
SAW:OFF		ADD. NOISE OFF	

SFN mode ON



SFN over ATSC M/H Characteristics

- Impact of Intrinsic BER on receiver threshold.

So small it
can't be
measured.
Conclusion:
No impact!

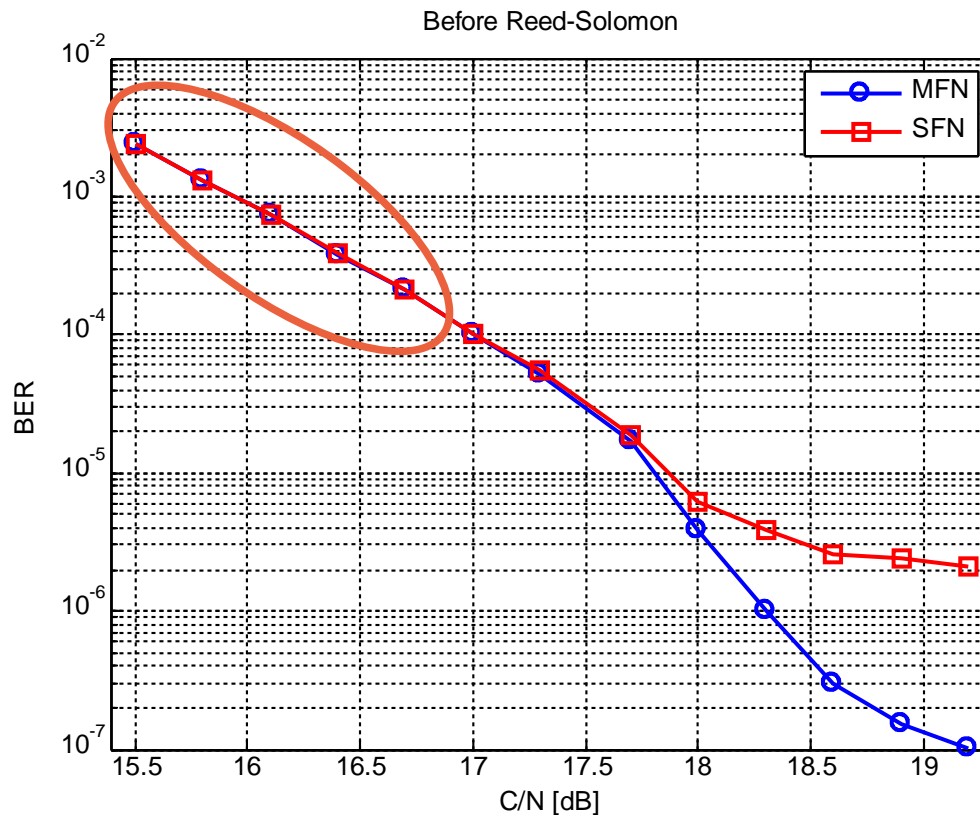

AT7001 – M/H / SFN READY

