

# Coverage issues in the DTV transition



Perry Priestley, Vice President, Linear Industries, Inc., September 2010

# Contents

- Moving to Digital

- Should you modify existing Analog equipment or buy new?

- Maximizing coverage

- SNR Improvement

- Gap Filling



# Contents

- ➡ Moving to Digital
  - ➡ Should you modify existing Analog equipment or buy new?
- ➡ Maximizing coverage
  - ➡ SNR Improvement
  - ➡ Gap filling



# Analog Transmitter: Upgrade or New?

Typical NTSC Analog transmitter

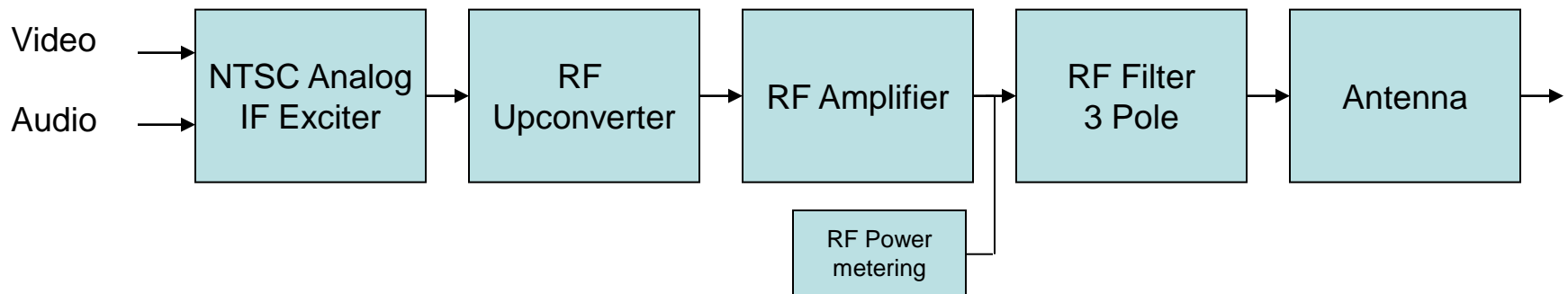

Typical ATSC Digital transmitter

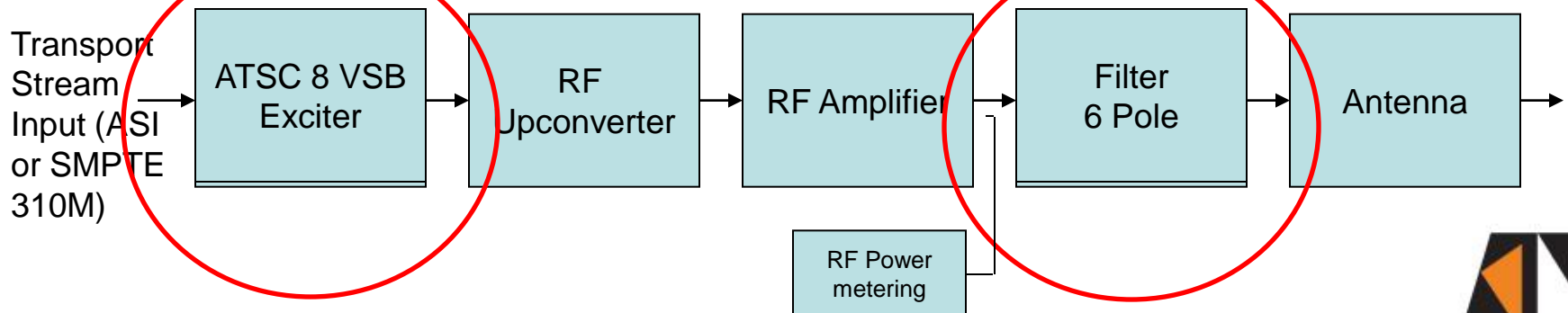

# Transmitters: Upgrade or New?

- Intermediate Power Amplifier or Pre-drivers
- Forward Error Correction (FEC)
- Final Amplifier type and age (high power amplifier)
- Monitoring, metering and protection system
- Filter
- Antenna



# Existing Analog translator... upgrade or new?

## How to choose?

1. Is your new licensed digital power less than 50% of your peak analog power?
2. Is your analog transmitter working properly
  - a. 100% power output?
  - b. Are the amps working properly: test = Good linearity (Low Frequency linearity, diff gain and diff phase)?
3. Can you still buy replacement parts? Do you still know how to fix it if it breaks?
4. Is your digital channel within a few channels of the Analog channel?
5. Same transmission location ?



# Digital Upgrade requirements

## Low Power (less than 5kW NTSC)

### Minimum needs

Approx. cost - CN

➔ Manual correction Exciter



\$8,500.00

➔ Six Pole mask filter



\$1,500.00

➔ Service install engineer



\$5,000.00

TOTAL

---

\$15,000.00

➔ A new 1kW transmitter costs about \$50k



# Digital Upgrade requirements

## High Power (greater than 5kW NTSC)

### Minimum needs

Approx. cost - CN

➔ Automatic correction Exciter



\$20,000.00

➔ Test and Monitoring options



\$6,000.00

➔ Six Pole mask filter

\$11,000.00

➔ Service install engineer



\$10,000.00

TOTAL

---

\$47,000.00

➔ A new 5kW ATSC transmitter costs about \$200k



# Upgrade or New: Conclusion

In most circumstances an existing Analog transmitter can be modified to Digital

- ➡ Automatic correction Exciter a must!
  - ➡ With MEC and CFR makes a big difference to coverage and efficiency
- ➡ Can cost only 25% of a new transmitter



# Methods to improve coverage : SNR

## Typical Analog Transmitter performance

Analog Transmitter Quality	Digital Exciter Quality	Analog Peak Sync / Digital Average Power	Maximum Output Power %
Quality*	Quality **	dB	(ref. PS analog pwr)
Poor	Poor	7.7	17
Medium	Poor	6.7	21
Good	Poor	6.1	25
Poor	Medium	5.2	30
Medium	Medium	4	40
Good	Medium	3.5	45
Poor	Good	3.5	45
Medium	Good	2.4	58
Good	Good	1.9	65

### Definitions

* Digital Exciter	Poor	<6dB correction (manual)
	Medium	>6<8dB correction, No MEC, CFR (manual)
	Good	12+dB correction, MEC and CFR (automatic)
** Analog Transmitter Quality	Poor	>15% LF Lin/Gain
	Medium	<10% LF Lin/Gain/Phase
	Good	<5% LF Lin/Gain/Phase

Based on 47dB shoulders / 27dB SNR (un-equalized)



# Contents

## ➡ Moving to Digital

➡ Should you modify existing Analog equipment or buy new?

## ➡ Maximizing coverage



# Coverage issues

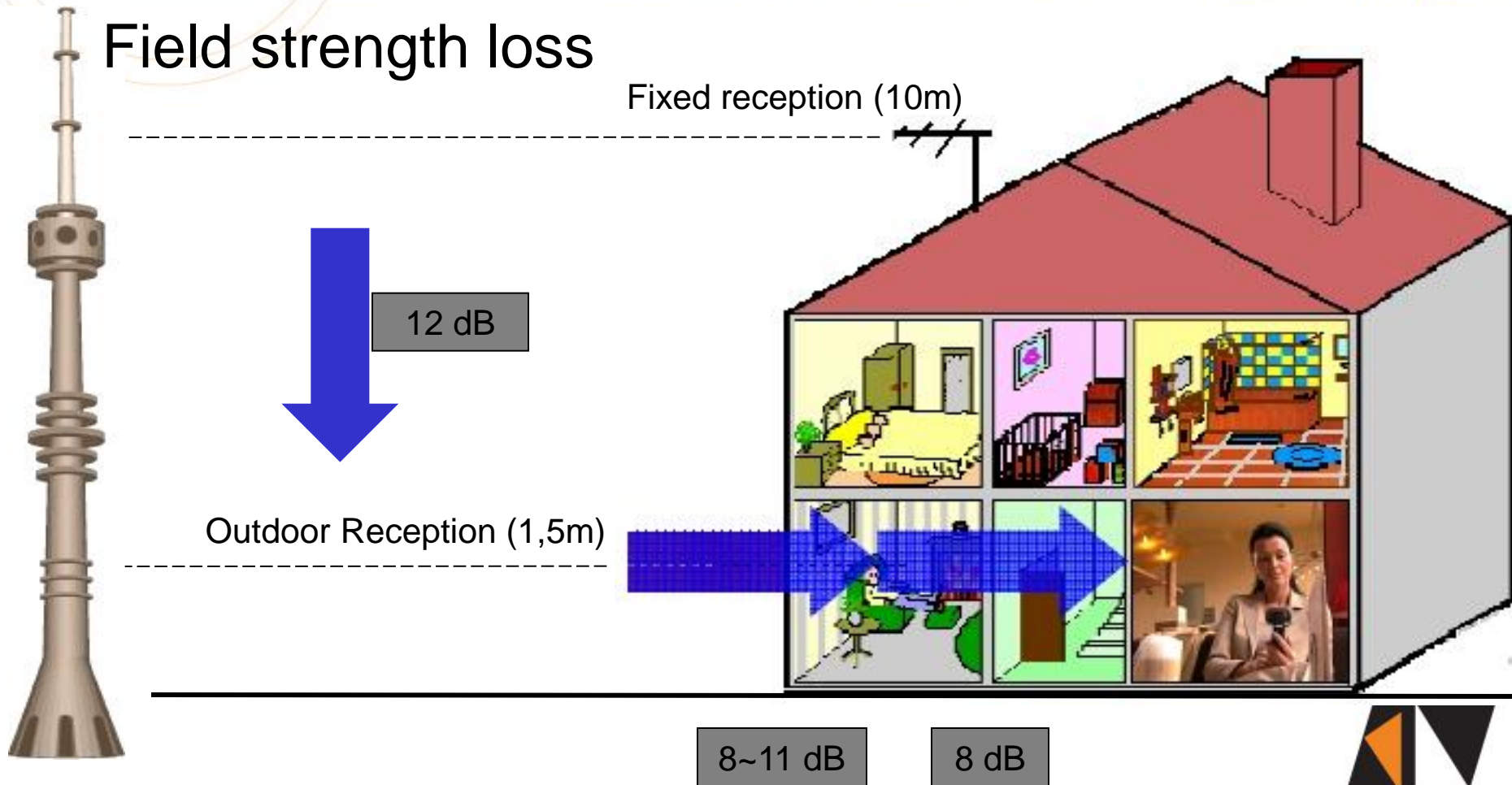

# Coverage issues

- ▶ ATSC signal attenuation can be as much as 10-20dB from outdoor to indoor reception
- ▶ M/H FEC means it can work at much lower S/N ratio .. Advantages are lost due to:
  - ▶ handheld unit antenna inefficiencies
  - ▶ Varying polarization as the unit is moved
  - ▶ Internal noise generated by the device
  - ▶ External noise from switching PSU's and other devices indoors
- ▶ Studies have shown that reliable outdoor reception of mobile ATSC requires a field strength  $>65\text{dBuV/m}$ .
- ▶ Which means  $>85\text{dBuV/m}$  for inside reception



# Methods to improve coverage

- Increase transmission power
  - But...
    - Interference limitations
    - Limitations from FCC/Industry Canada
    - Difficult to reach areas: Sports stadiums, Under ground locations, Shopping malls
- Change antenna pattern elliptical polarization

OR (and)

- Maximize the transmitters SNR/MER
- Install Gap fillers



# Methods to improve coverage : SNR

Given a power amplifier being driven by an 8VSB signal, consider three “figures of merit”:

Output Power

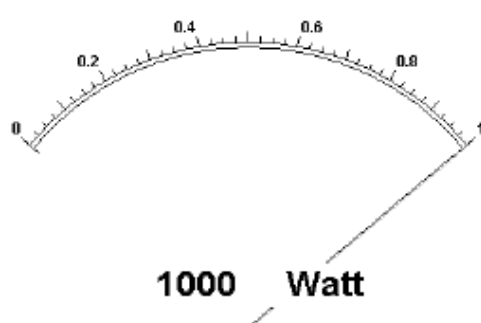

Intermodulation

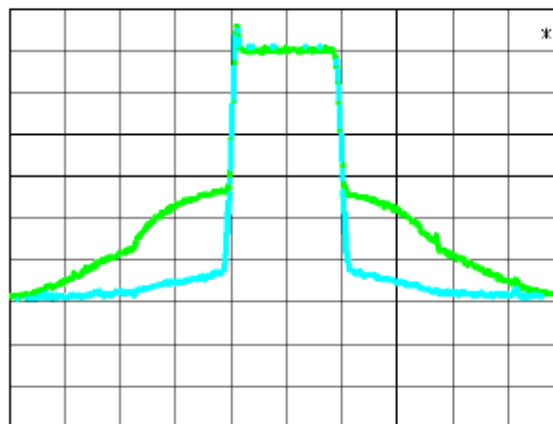

MER

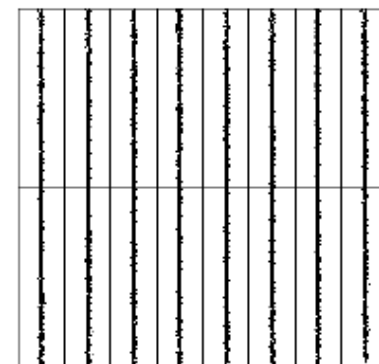

# Methods to improve coverage : SNR

## What is the best SNR?

- ▶ Threshold SNR of ideal ATSC demod ~ 15.2dB
- ▶ 27dB SNR/MER assumed level for maximum coverage
  - ▶ But based on Rx being connected directly Tx!
- ▶ Real world SNR degraded by:
  - ▶ Filter, antenna, co-channel and adjacent interference, echoes, Rx equalizer white noise (dependant on echoes), Rx inter-modulation and cross-modulation,.
  - ▶ Also Rx input antenna miss-match
  - ▶ Unlicensed devices can also degrade SNR
- ▶ So if not 27dB ... what should the best or optimum SNR be?



# Methods to improve coverage : SNR

## What is the best SNR?

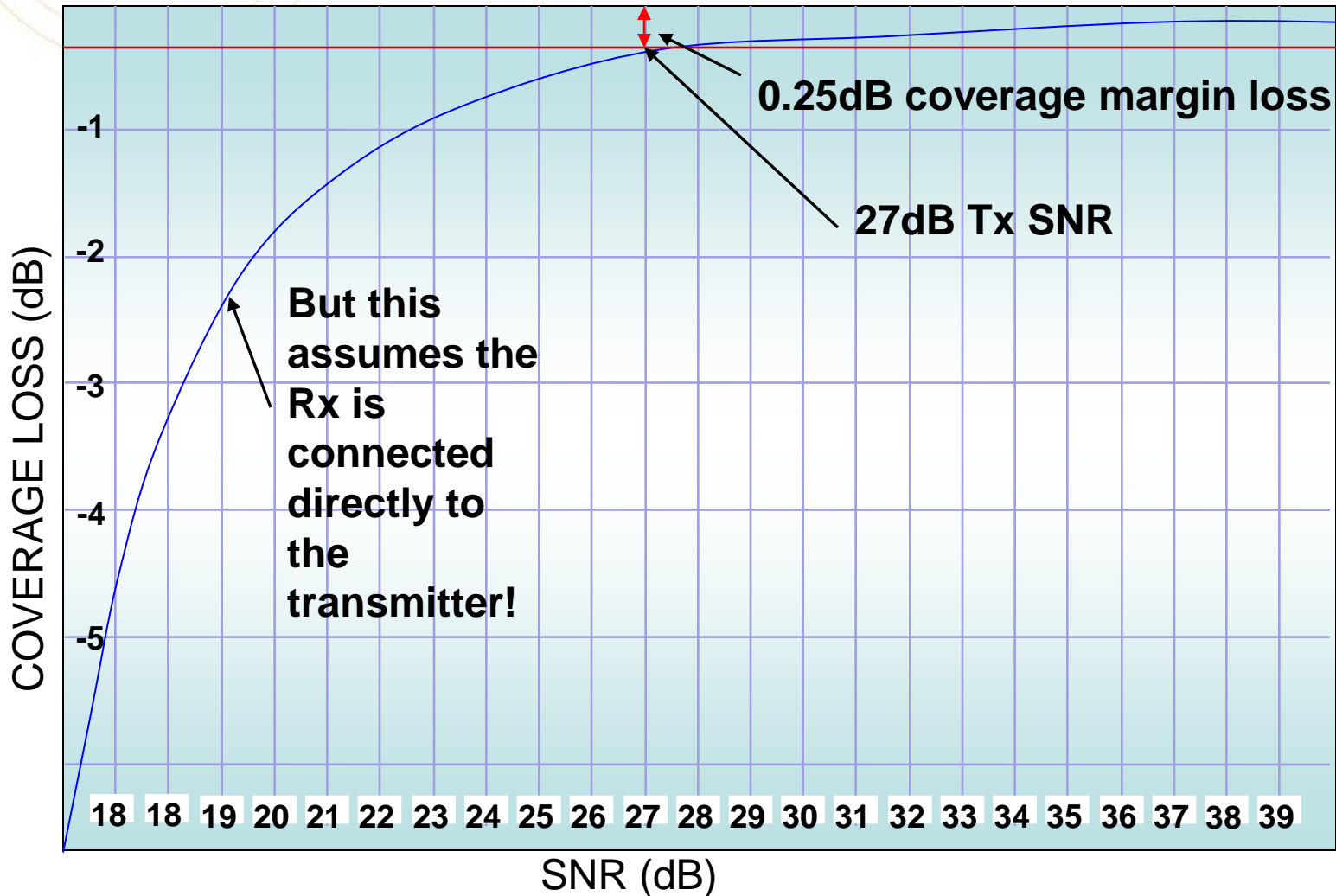

# Methods to improve coverage : SNR

## What is the best SNR?

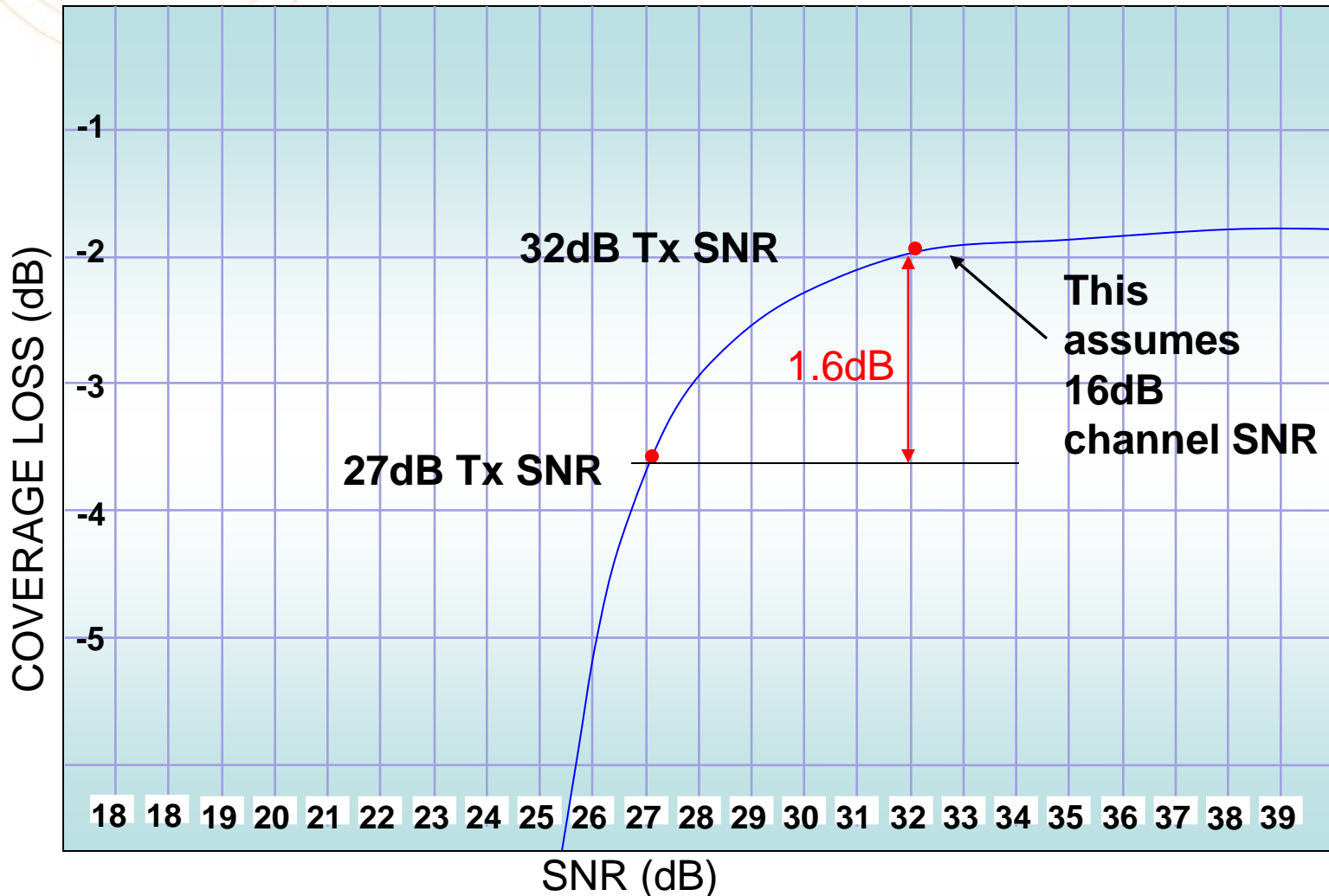

# Methods to improve coverage : SNR

## Causes of poor SNR

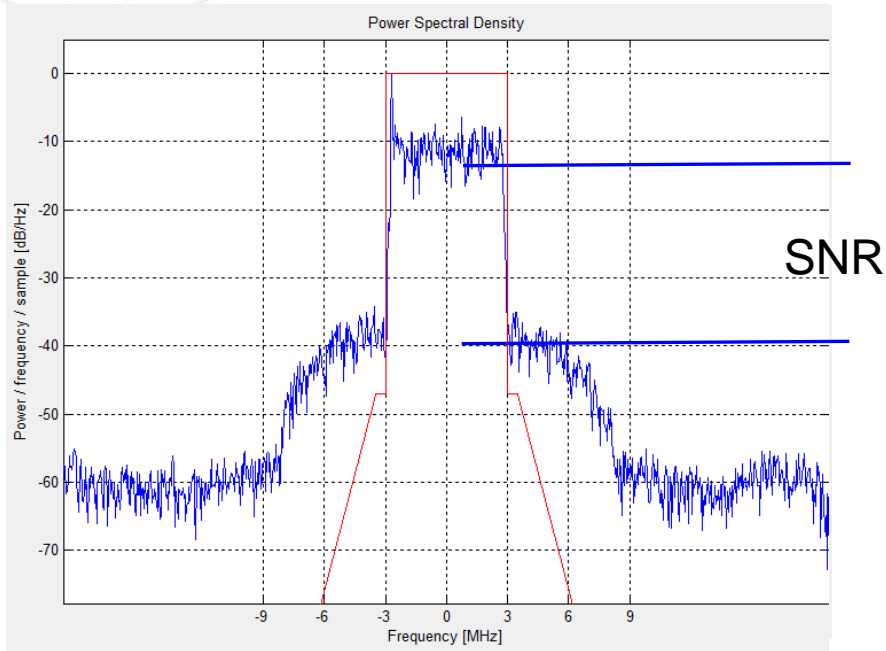

- Modulator
- Transistorized amplifier
- IOT/Tube amplifier
- Pre-amplifiers stages
- FEC
- Or any amplitude distortion

## Inter-modulation (non-linearity)

- 3<sup>rd</sup> Harmonic distortion or
- Re-insertion of the sidebands



# Methods to improve coverage : SNR

## Causes of poor SNR

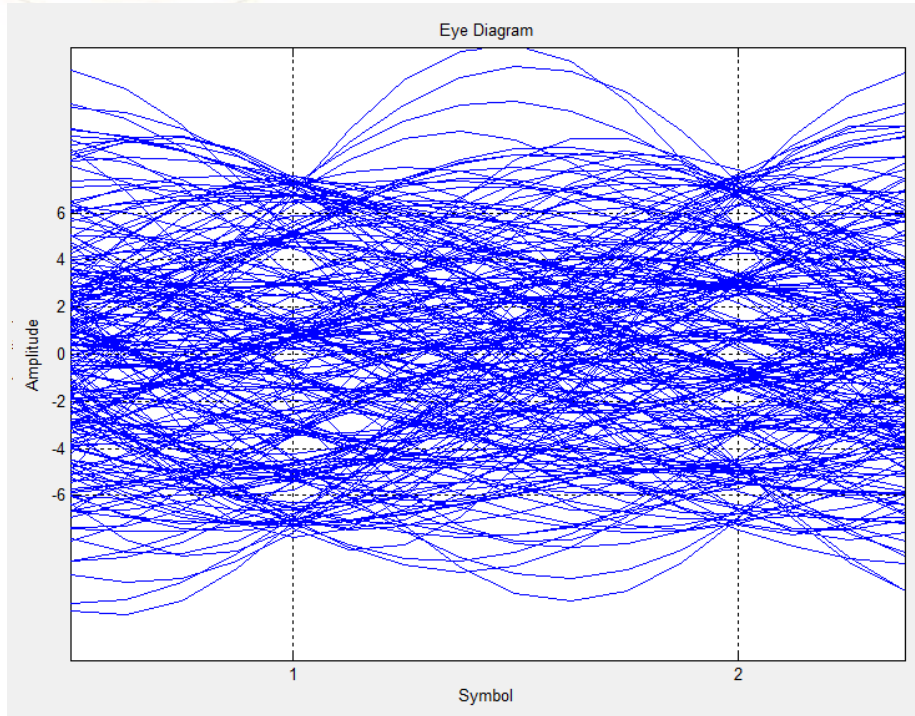

- Harmonic Filters
- Mask or Band Pass filters
- Combiners
- Splitters
- Phasing Sections
- ~ Frequency/Amplitude or Phase anomaly

Non-Equalization (Linear distortion)



# Methods to improve coverage : SNR

## Typical Analog Transmitter performance

- ➡ Analog transmitter must start off with reasonable performance in terms of non-linearity, differential gain and phase, frequency response and group delay.
- ➡ When modified to Digital operation the uncorrected performance is typically as follows:
  - ➡ 37 - 42dB shoulder levels
  - ➡ 22 - 24dB MER before filter
  - ➡ 17 - 22dB MER after filter
  - ➡ 2 - 4 degrees phase error
  - ➡ 1 - 4 dB amplitude distortion

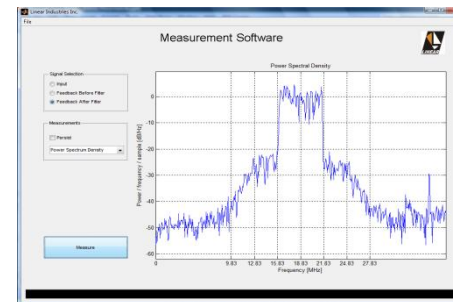
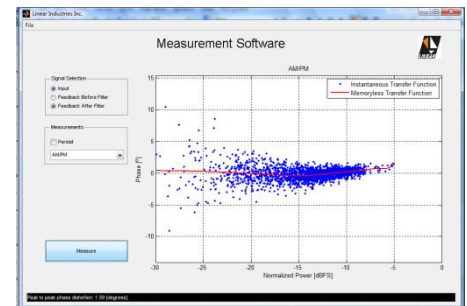
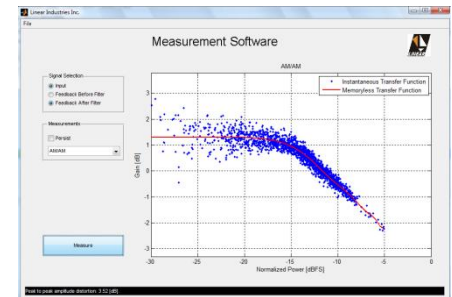

# Methods to improve coverage : SNR

## Typical Analog Transmitter performance

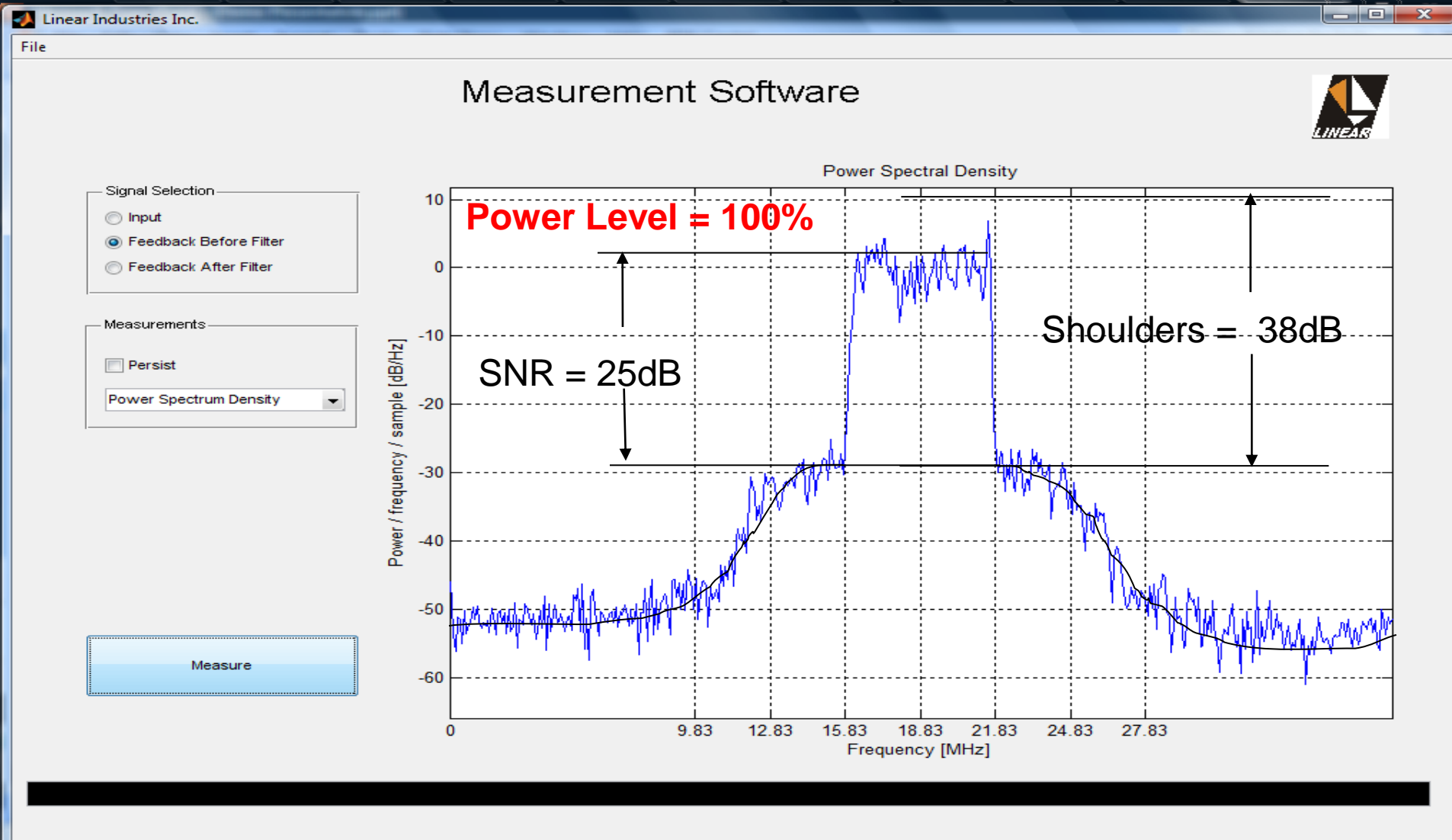

# Methods to improve coverage : SNR

## Typical Analog Transmitter performance

Linear Industries Inc.

File

### Measurement Software



Signal Selection

Input

Feedback Before Filter

Feedback After Filter

Measurements

Persist

Power Spectrum Density

Measure

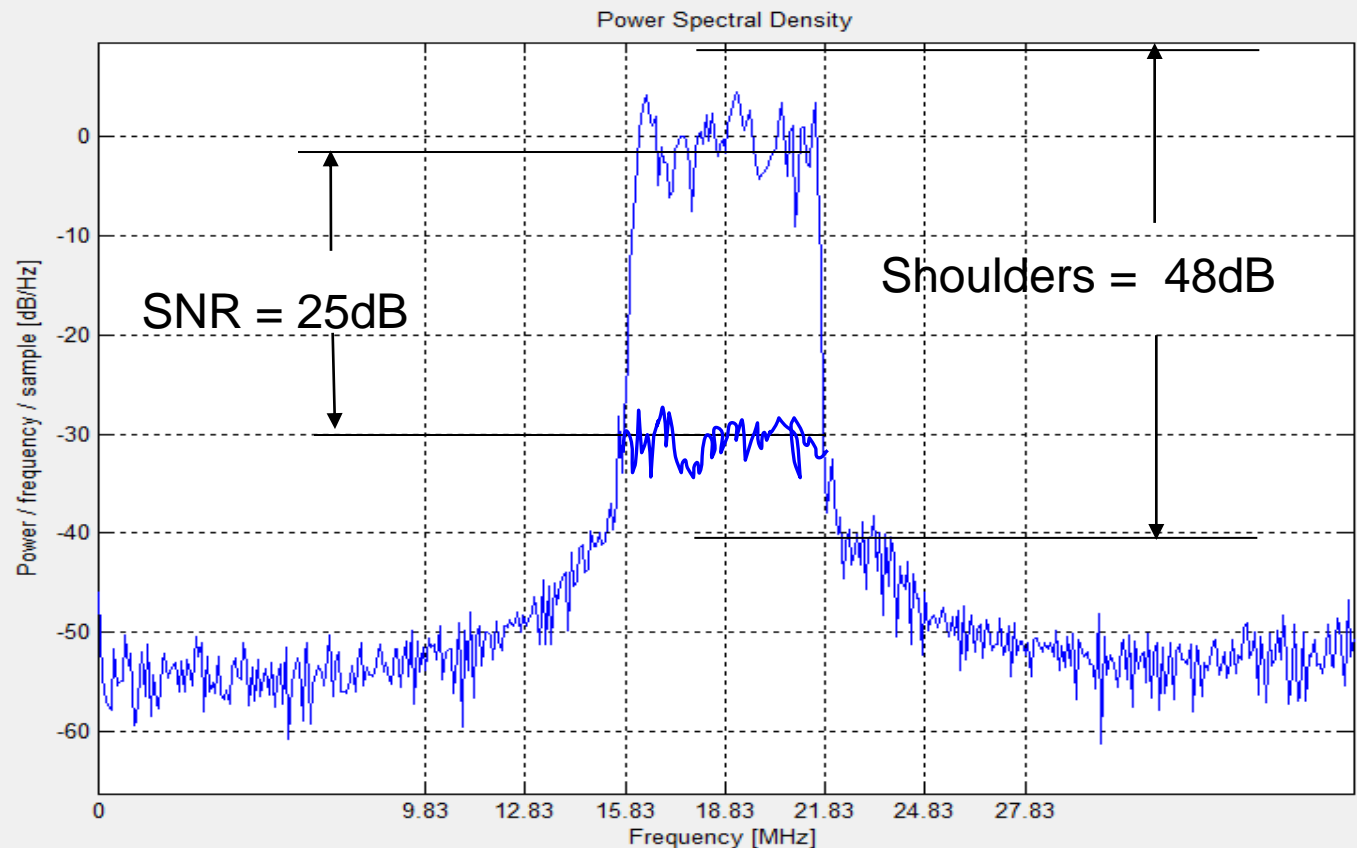

# Methods to improve coverage

➔ There are three key digital performance enhancements that can significantly benefit coverage and cost of operating a digital transmitter:

1. Automatic Error correction – Linear and Non-linear
2. Memory Error Correction (MEC)
3. Crest Factor reduction (CFR)

➔ HIGHEST POWER AMPLIFIER EFFICIENCY

➔ 14 -> 19%

➔ HIGHEST WATTS / DOLLAR

➔ ANALOG PEAK SYNC / 8 VSB DIGITAL AVERAGE POWER RATIO OF 1.9dB (or 65% of peak sync power)

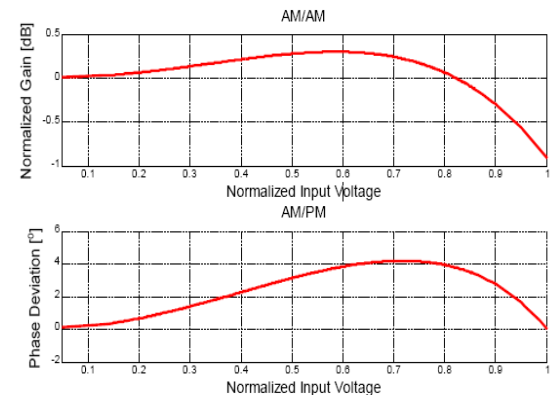

# Methods to improve coverage

## Memory Error Correction

- ▶ PA “Memoryless” or **Static** Characteristic

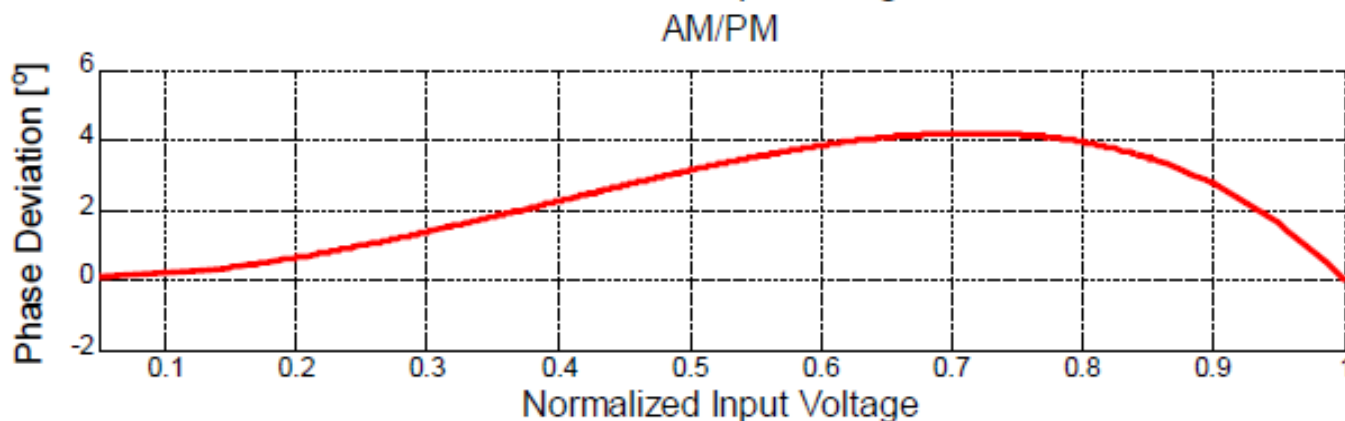
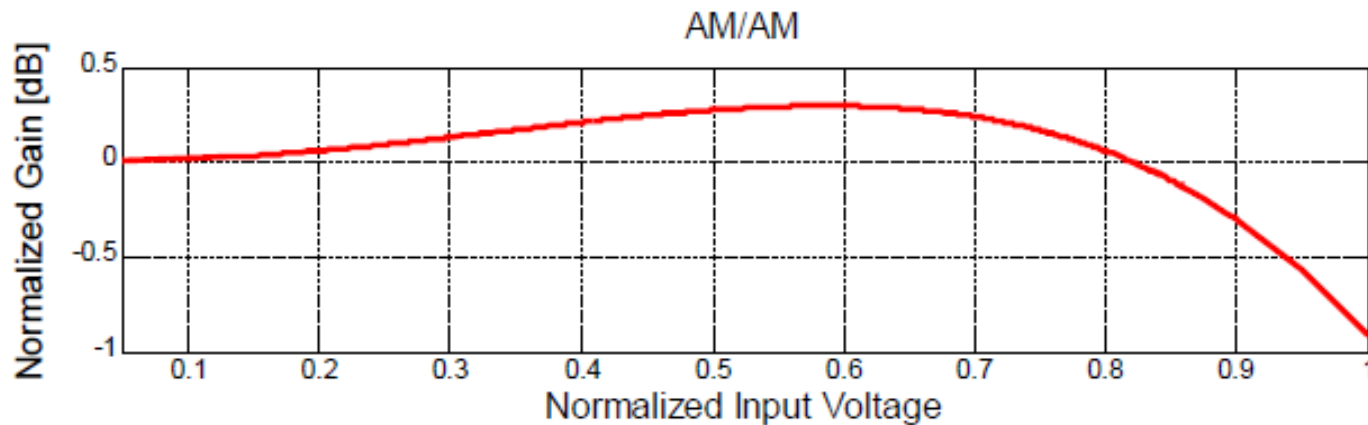

# Methods to improve coverage

## Memory Error Correction

- ▶ PA “Memoryless” or **Static** Characteristic and PA Memory or **Dynamic** characteristics

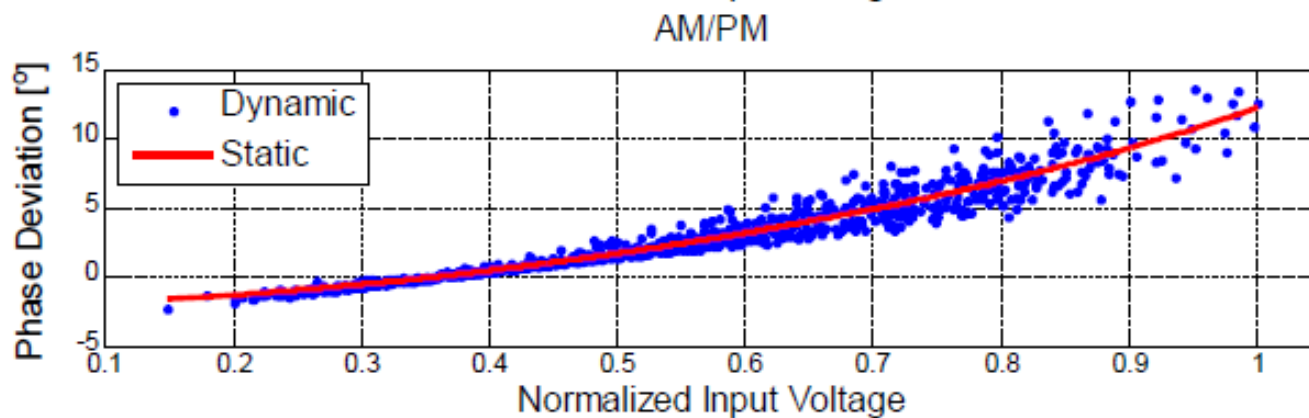
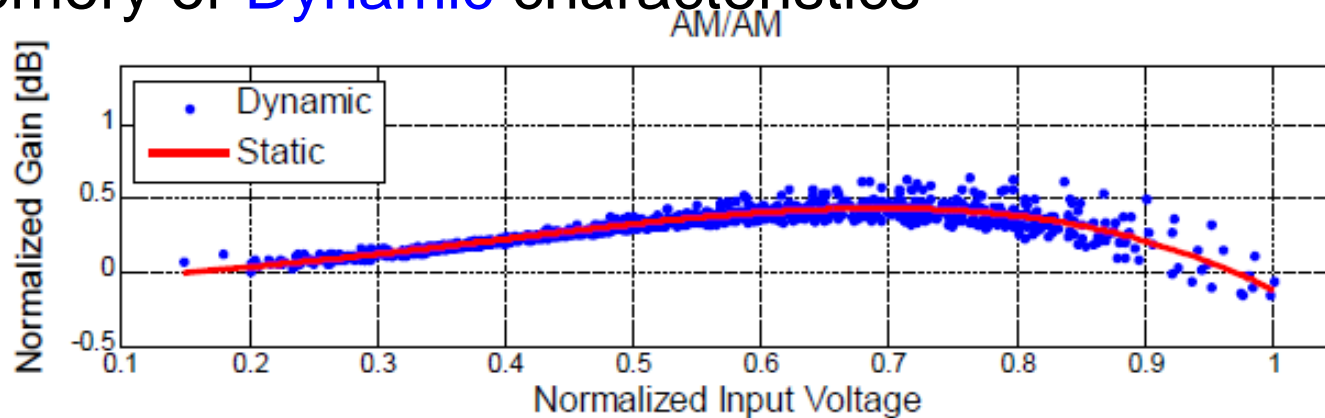

# Methods to improve coverage Memory Error Correction

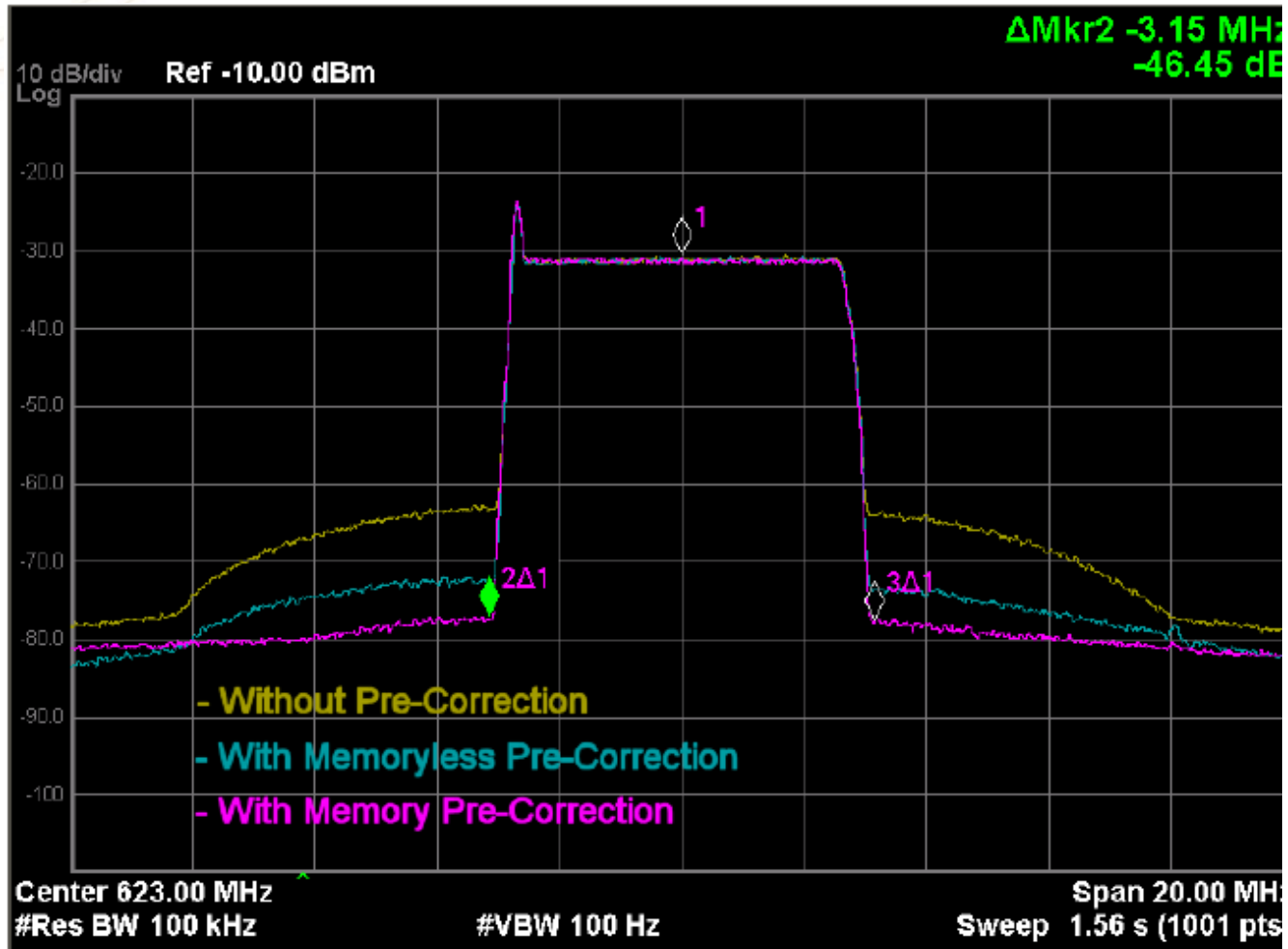

# Methods to improve coverage

## Crest Factor Reduction

- ▶ Reducing the peak envelope level
  - ▶ Without distorting the signal consequently increasing 3<sup>rd</sup> Harmonic distortion

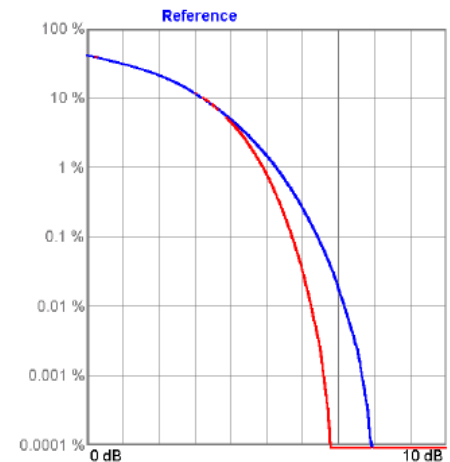
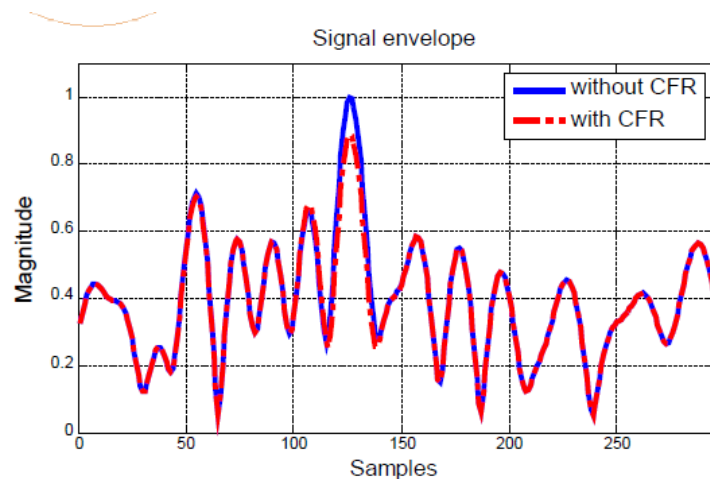

# Methods to improve coverage Crest Factor Reduction

## Without CFR

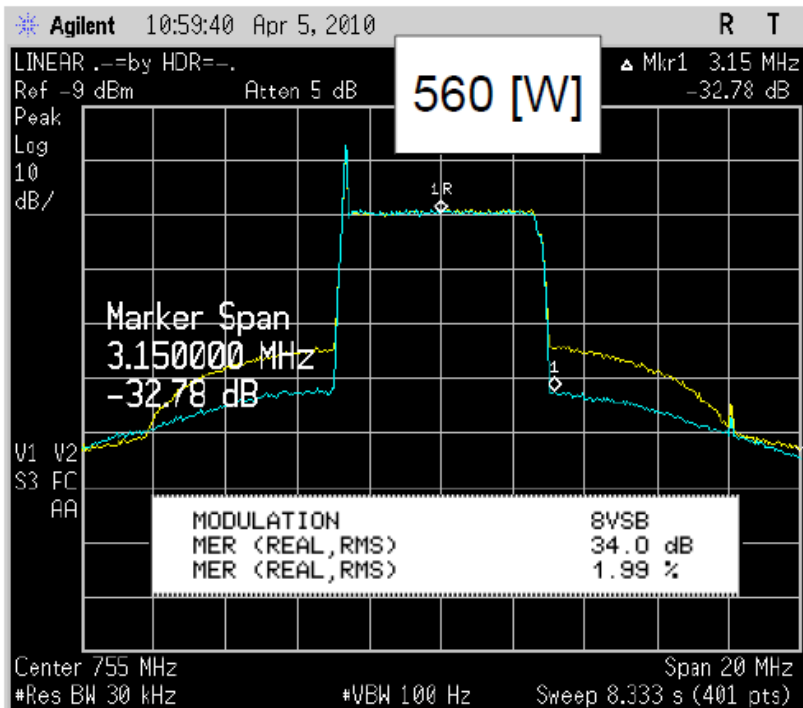

## With CFR

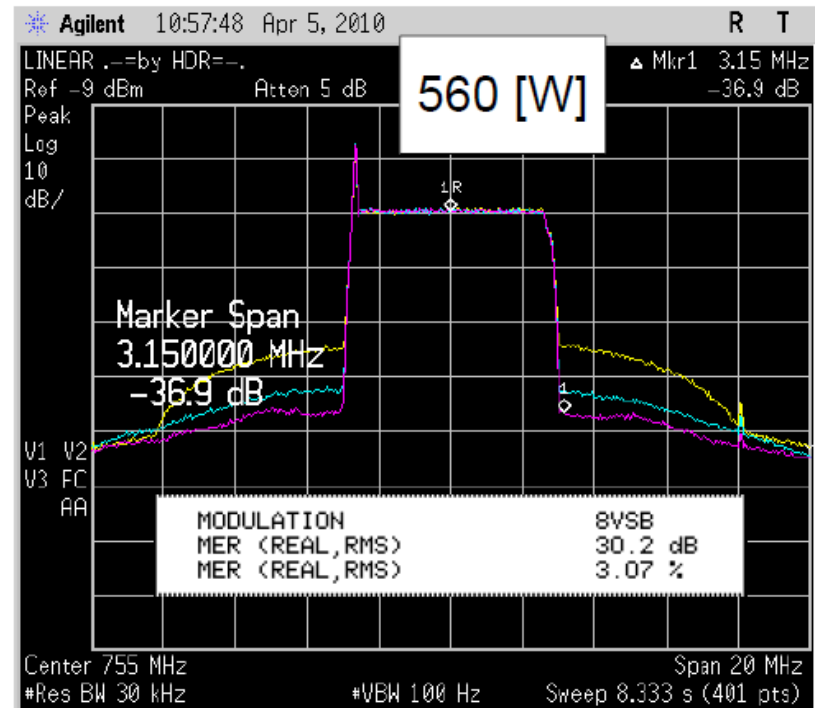

# Methods to improve coverage

## Crest Factor Reduction

### Without CFR

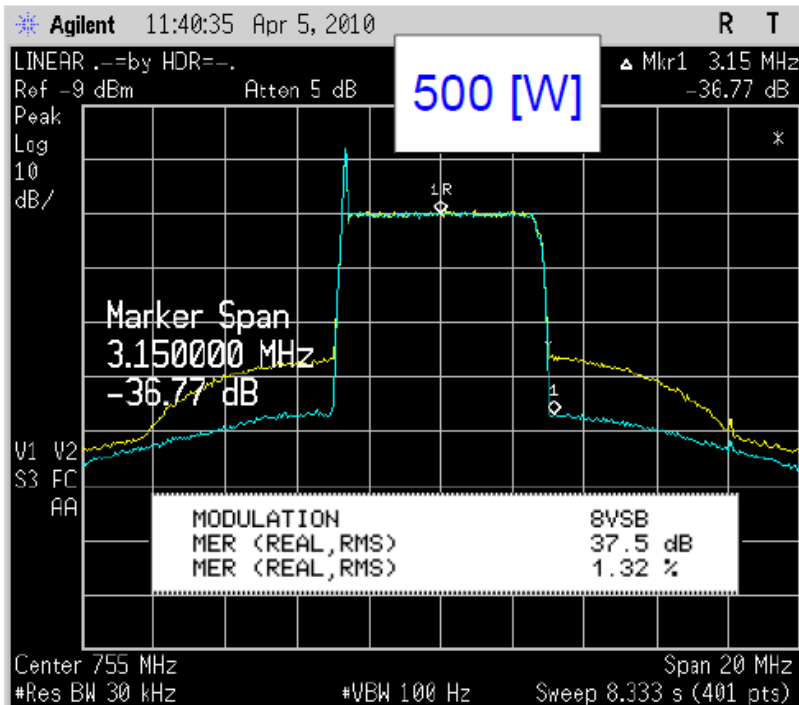

### With CFR

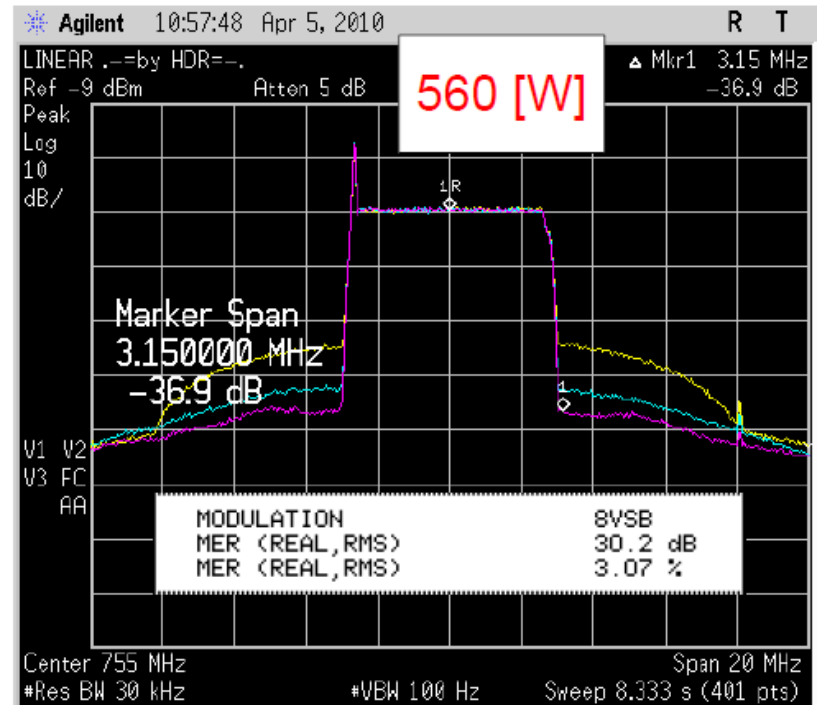

# Methods to improve coverage

## Summary

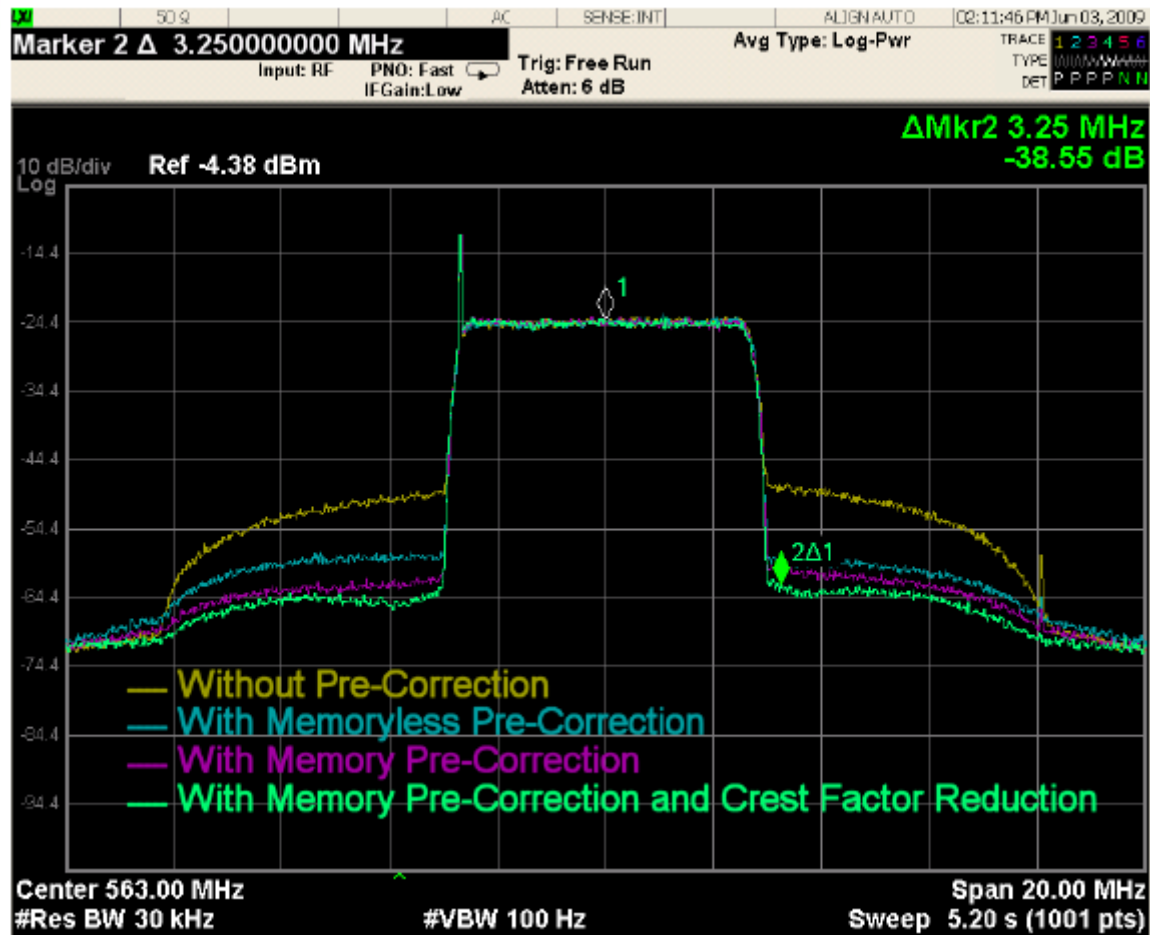

# Methods to improve coverage

## Gap Fillers

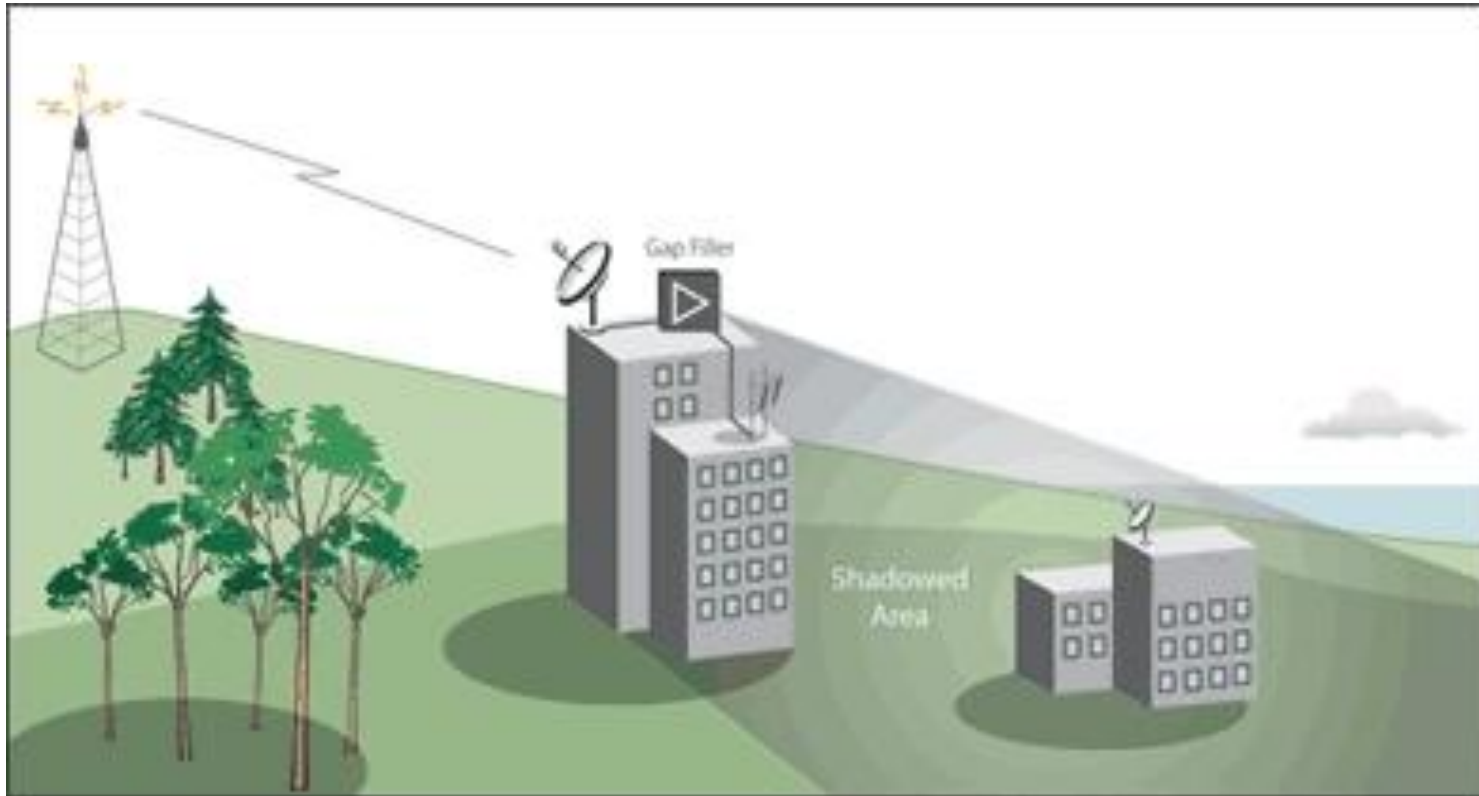

**Cover a Shadow Area**



# Methods to improve coverage

## Gap Fillers

- ❑ Key characteristics of echo cancellation:
  - ❑ Cancellation is critical for On-channel Repeaters
  - ❑ First echo rejection  $> 15$  dB
  - ❑ Maximum relation of coupling ratio:  $-1$  dB
  - ❑ APL (Automatic Power Limitation)



# Methods to improve coverage

## Gap Fillers

It is necessary to only re-transmit the channel of interest

Trade-off between delay and selectivity for digital filters:

- More selectivity, more transit delay
- Less selectivity, less transit delay

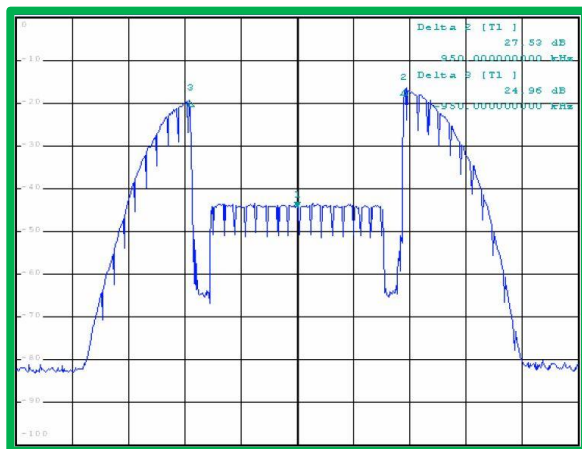

2  $\mu$ s

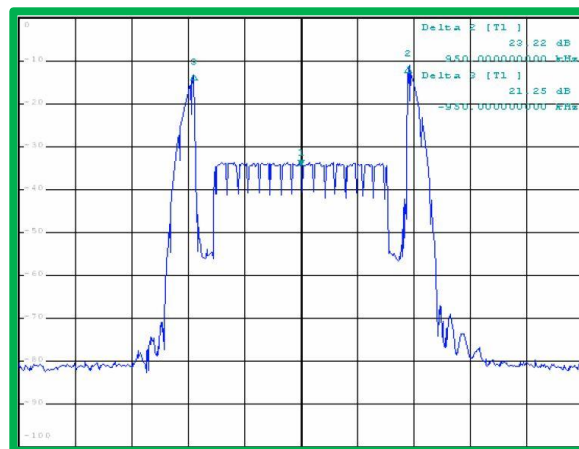

4  $\mu$ s

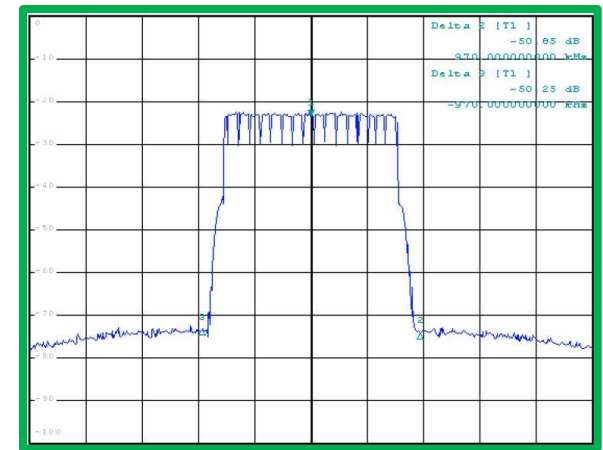

6  $\mu$ s



# Methods to improve coverage

## Gap Fillers

### Key Benefits

- Cover shadows and extend to lost zones
- Recoup lost audiences & Ad Revs
- No need for higher power Tx to reach lost customers
- Prepare & increase “Cellular-like” density to deliver Mobile TV

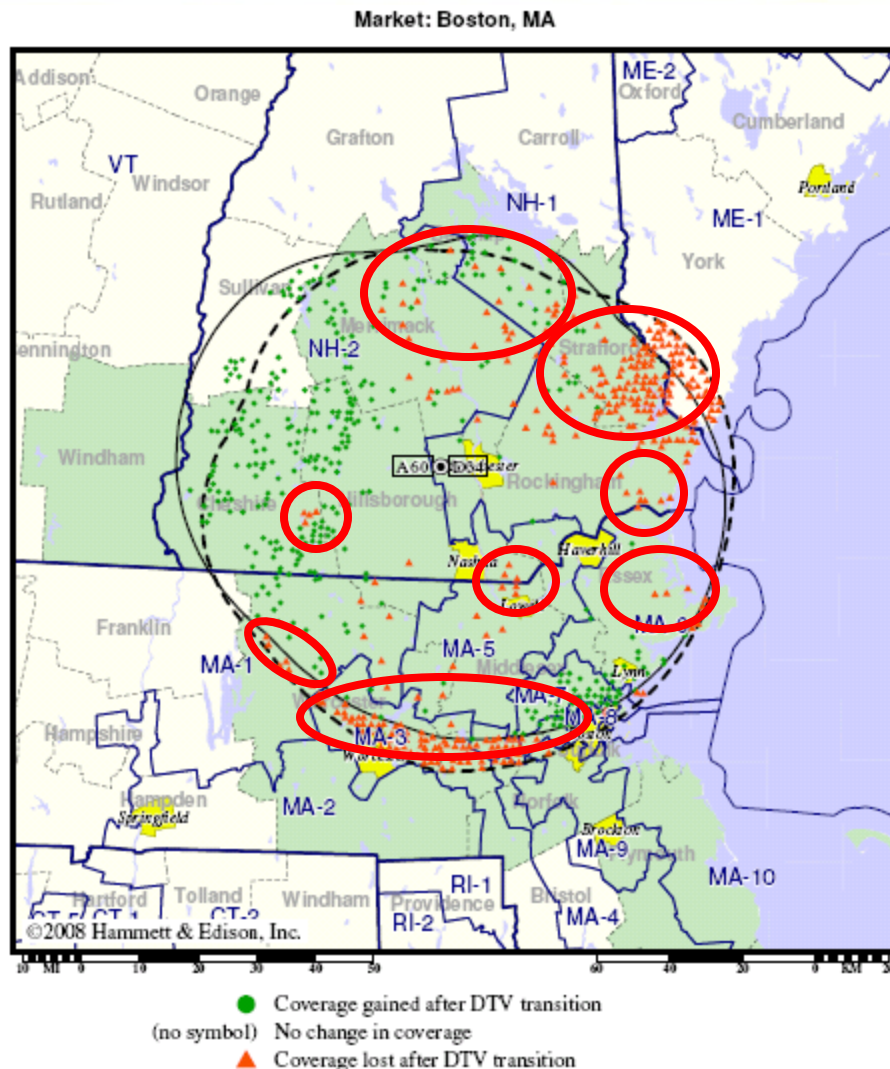

# Methods to improve coverage:

## Conclusion

- Modifying your analog can be done effectively and at relatively low cost
- Reliability = Noise Margin
  - Noise Margin maximized by improving SNR
- Most transmitters can be modified from digital but be careful!
- Key component is the exciter – Good coverage – lower cost of operation
- Gap fillers are likely to be the lowest cost method of ensuring maximum coverage



Thank you

Thank you for your attention

For more information contact  
[perry.priestley@linear-tv.com](mailto:perry.priestley@linear-tv.com)

